

# **Laboratório de Arquitetura II**

**2º semestre**

Madalena Carvalho

# ÍNDICE

## Sítio

Fotografias da maquete 1:1000

Desenho de análise do lugar

Fotografias da maquete proposta 1:1000

## 2ª Fase

### Lado Poente

#### Proposta

Imagem de referência

Citação – Síntese da proposta

Esquiço de síntese

Fotografias da maquete 1:200

Plantas e perfis 1:200

Fotografia da maquete espaço relevante 1:50 (facultativo)

Desenho(s) complementar(es) / visão serial

Fotografias das maquetes de trabalho (várias escalas)

## 1ª Fase

### Lado Nascente

#### Proposta

Imagem de referência

Citação – Síntese da proposta

Esquiço de síntese

Fotografias da maquete 1:200

Planta e perfil de conjunto

Fotografias da maquete 1:50 / 1:20 / ...

Planta e corte 1:50

Desenho(s) complementar(es) / visão serial

#### Processo

Desenhos exploratórios mais relevantes

#### Leituras comentadas

**Sítio**

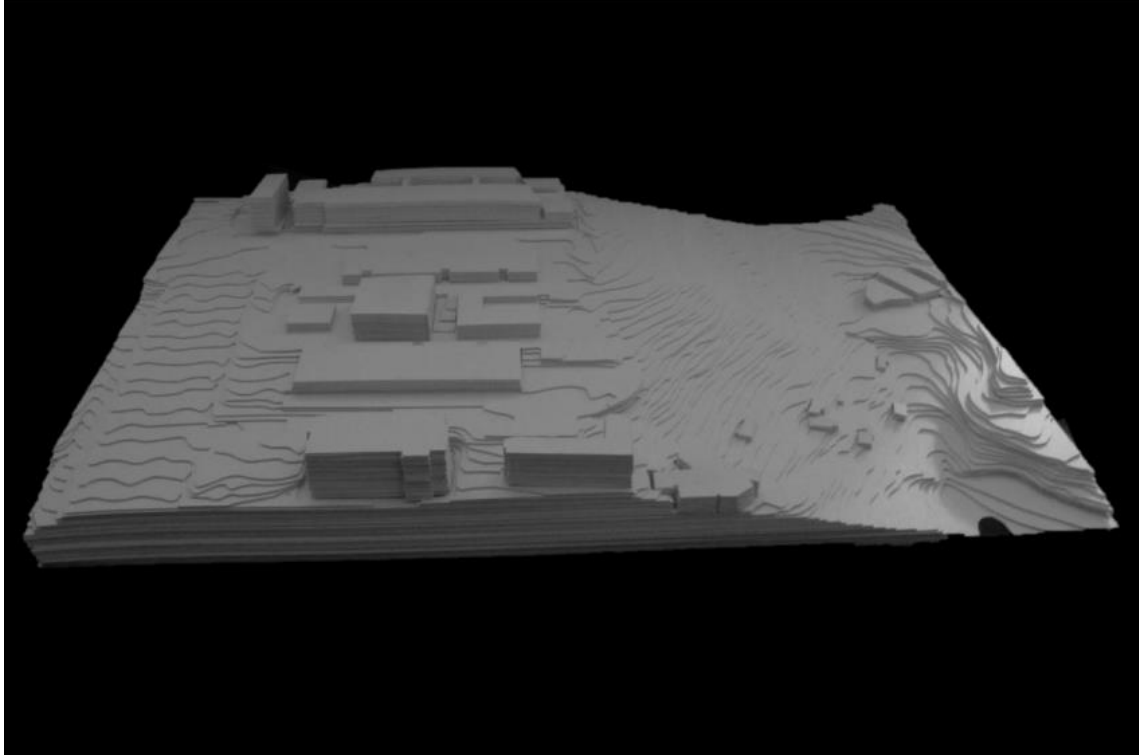

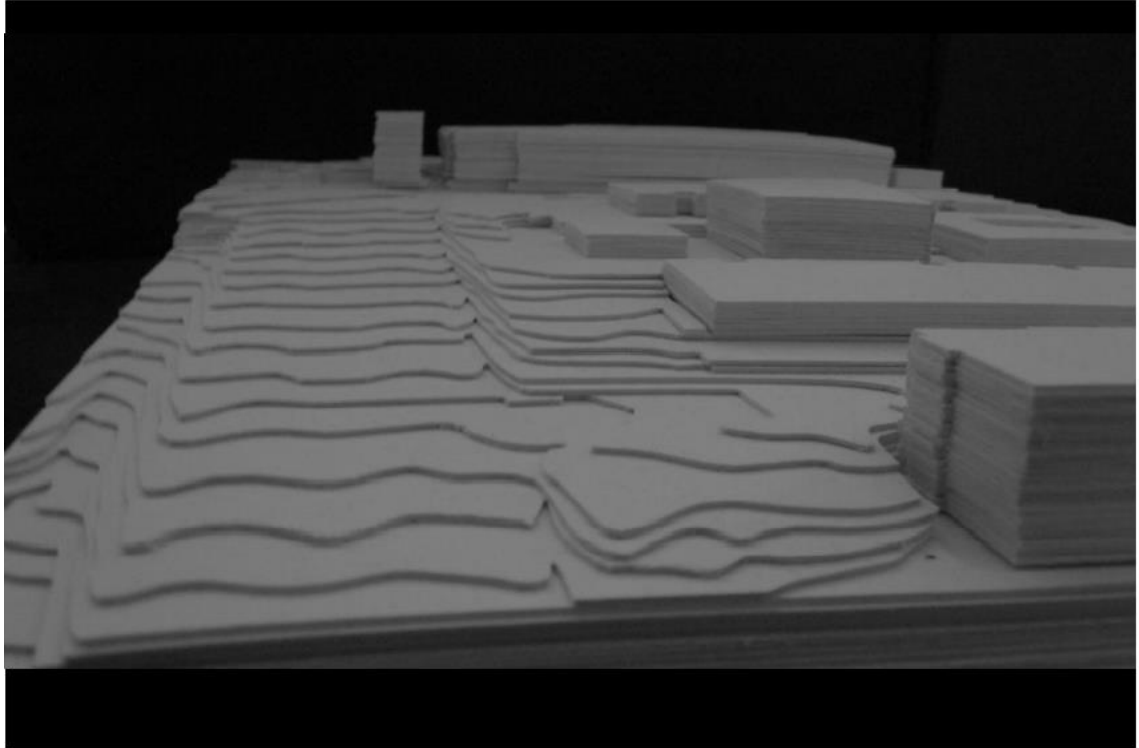



Planta 1:1000

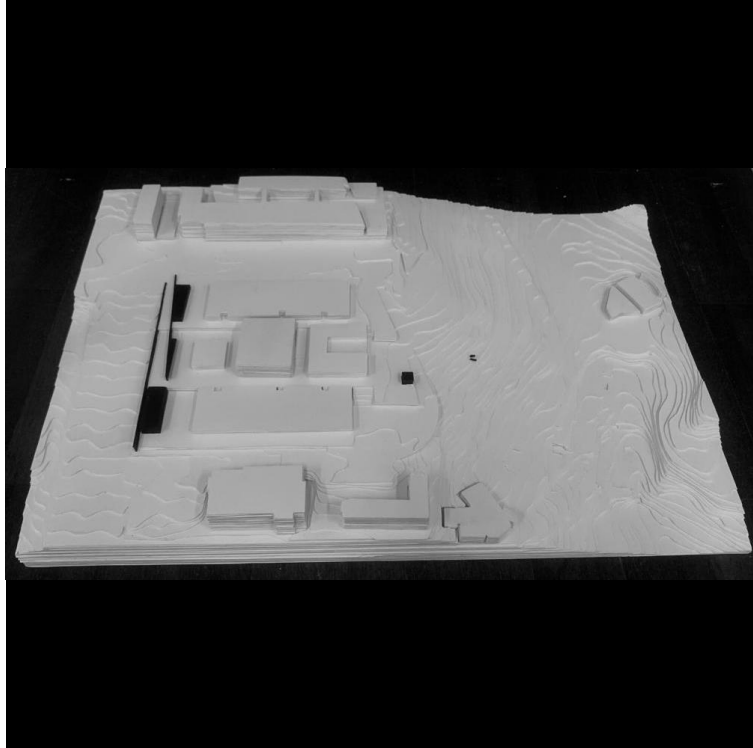

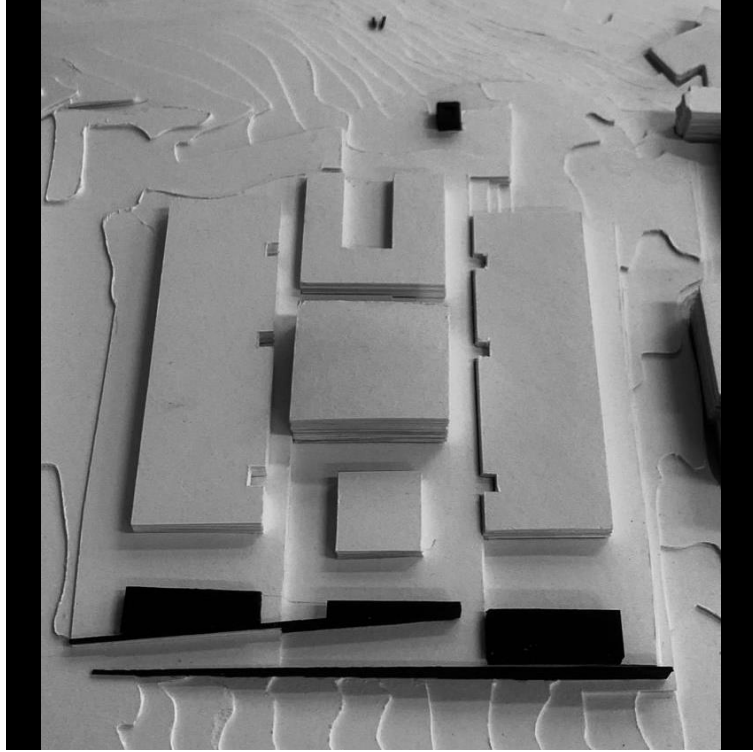



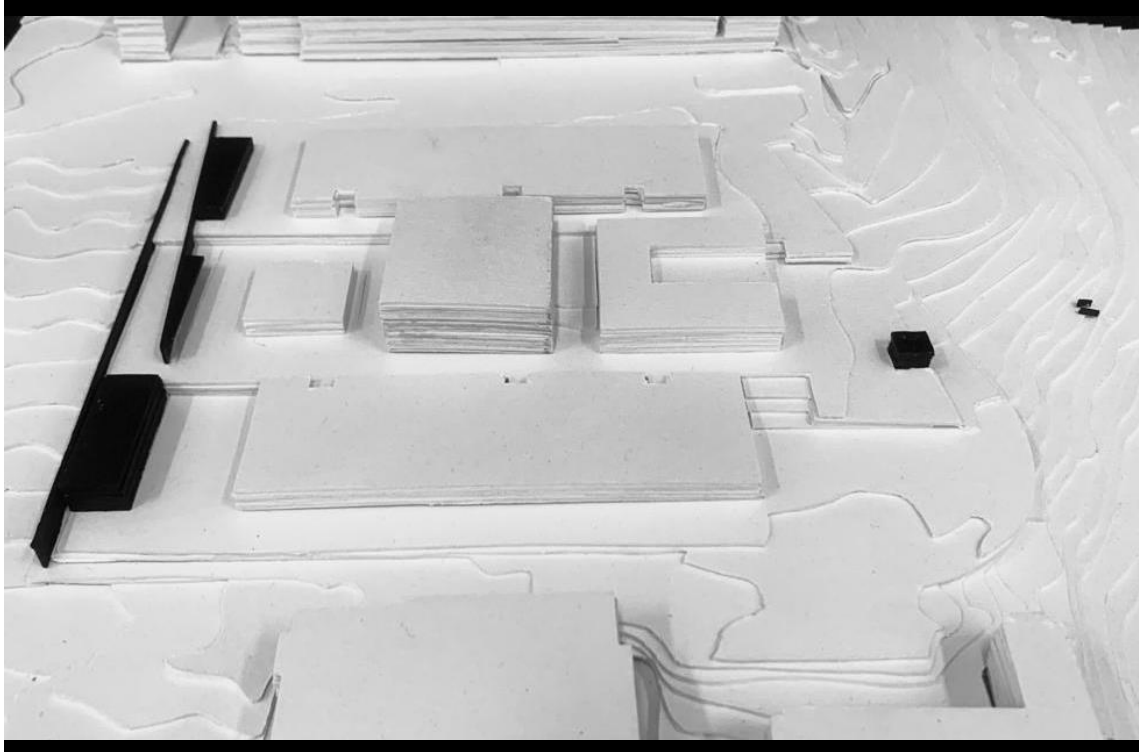



# 2ª fase

lado poente

**Proposta**



Piscinas de Marés de Leça da Palmeira, Álvaro Siza Vieira



Galeria da utopia, KAAAN Arquitetos

*“(...) i want to think about the artificial light in my buildings, in our cities and in our landscapes, and i catch myself forever returning, like a lover, to the object of my admiration: the light thats meats the earth from afar, the untold numbers of bodies, structures, materials, liquids, surfaces, colours and shapes that radiate in the light.”*

Peter Zumthor, *“Thinking Architecture”*

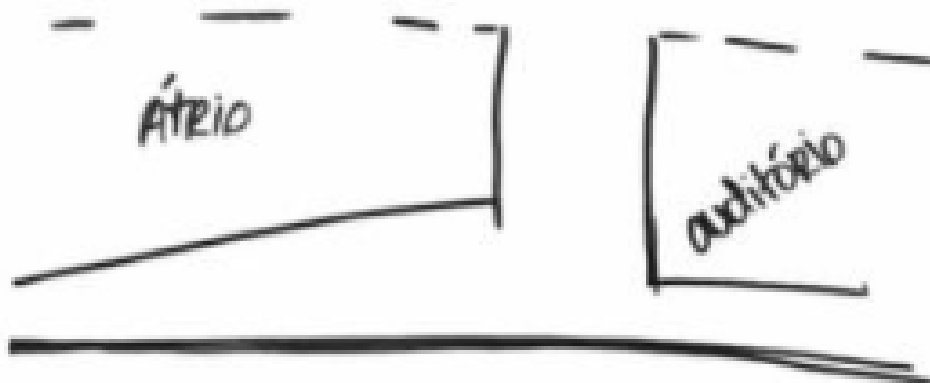

esquiço síntese



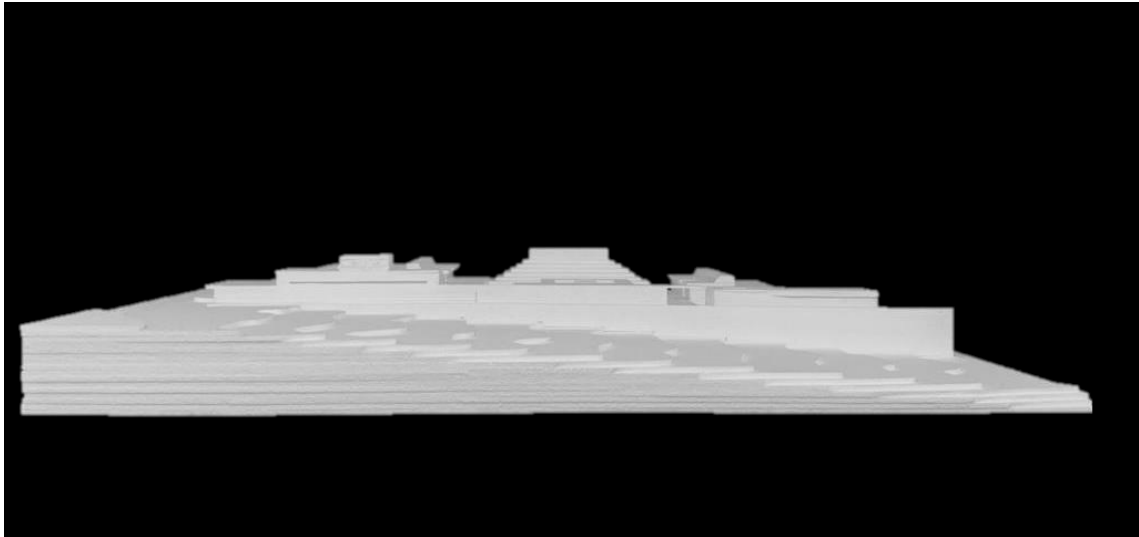

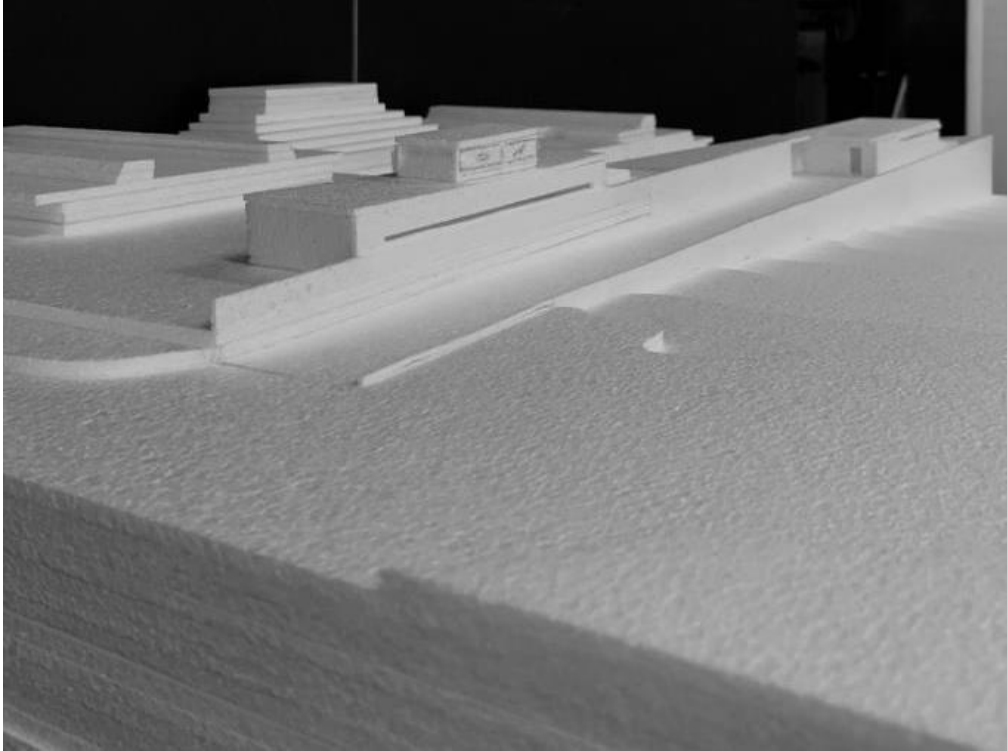

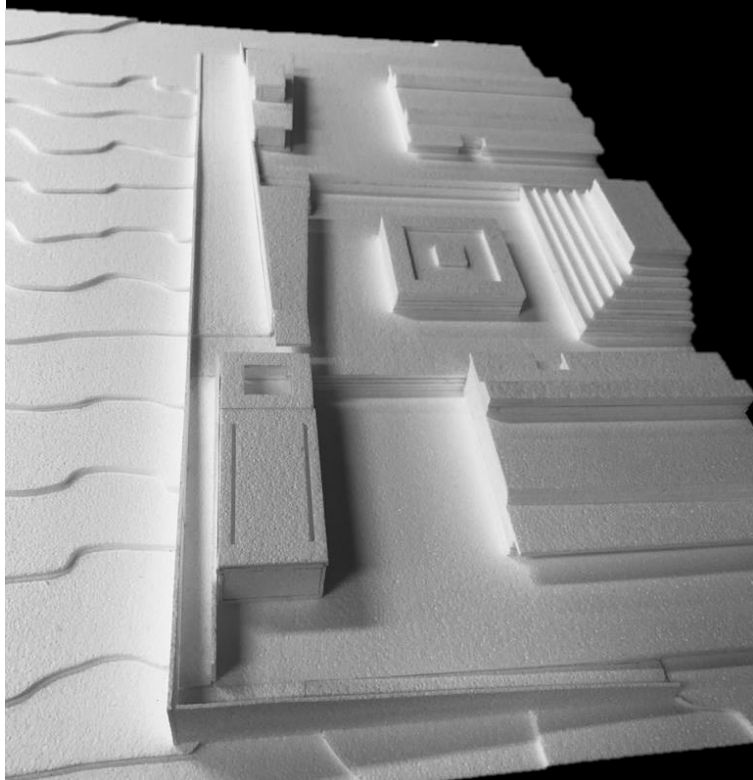

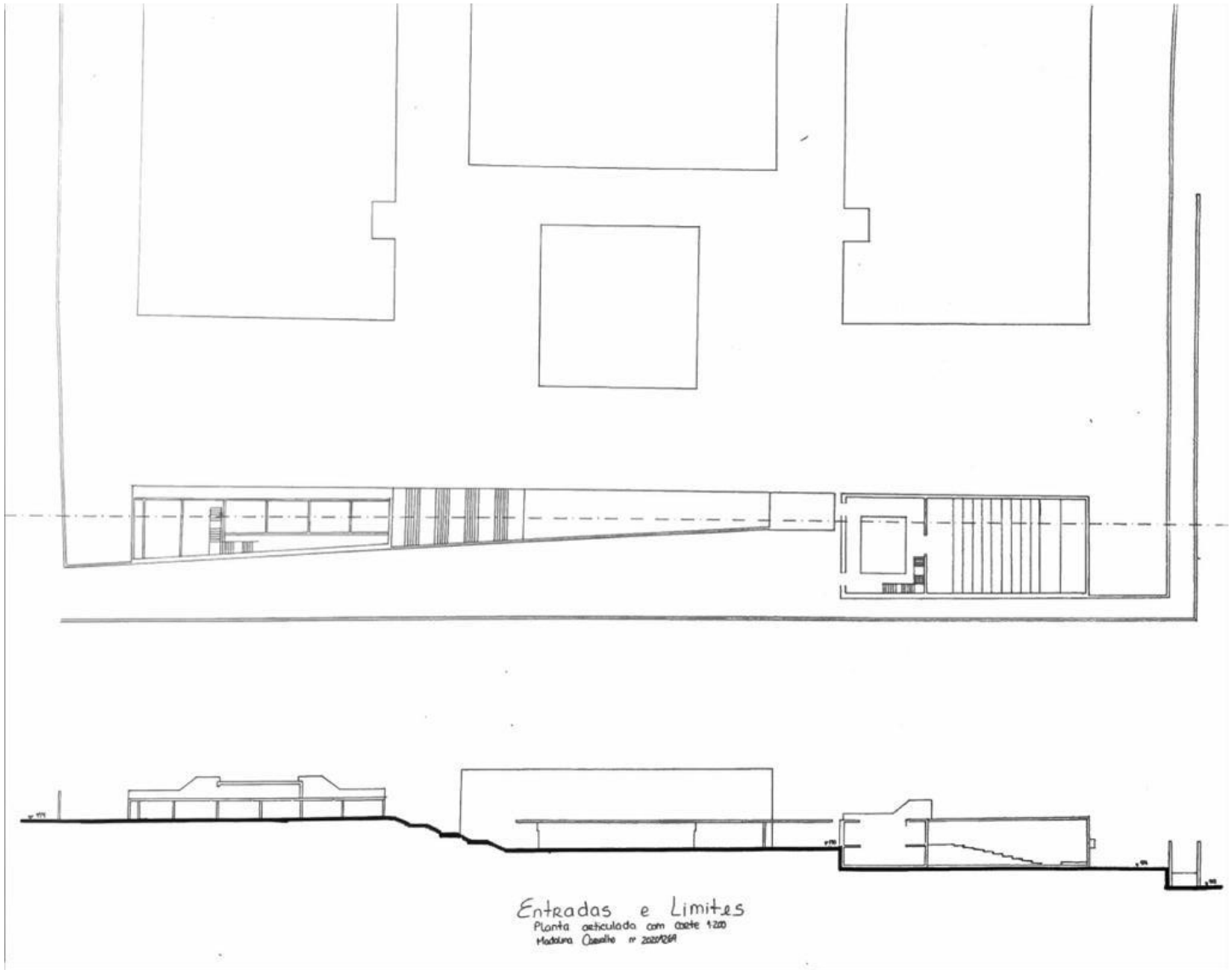

Planta e perfil de conjunto escala 1:200

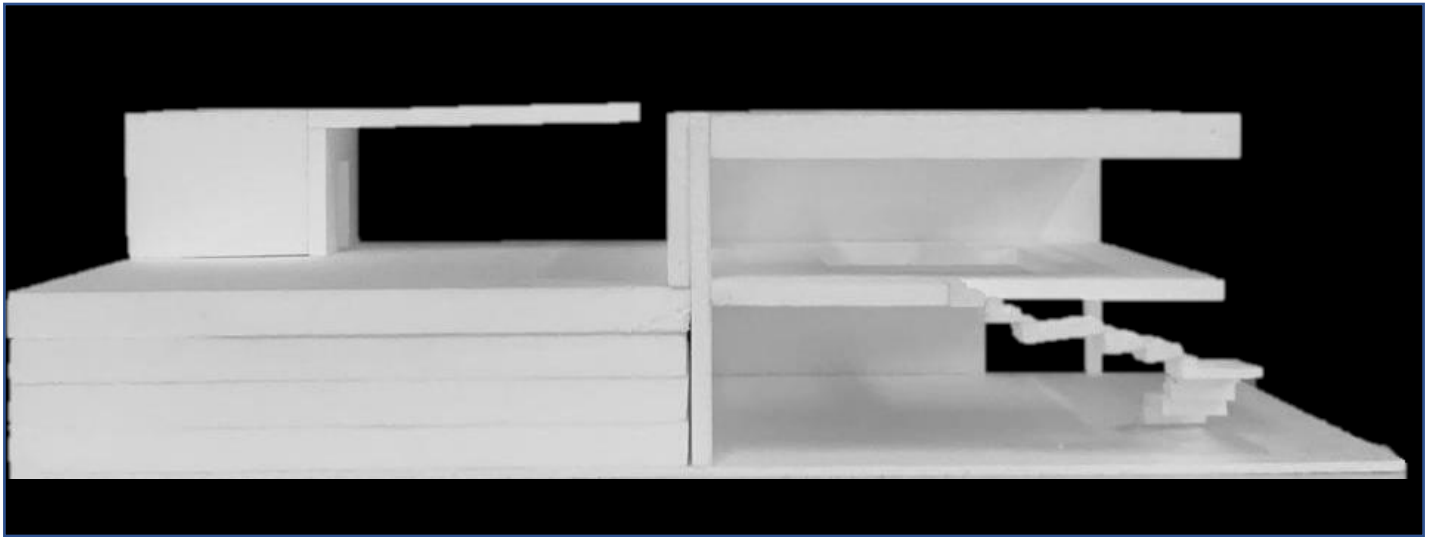

desenho(s) complementares

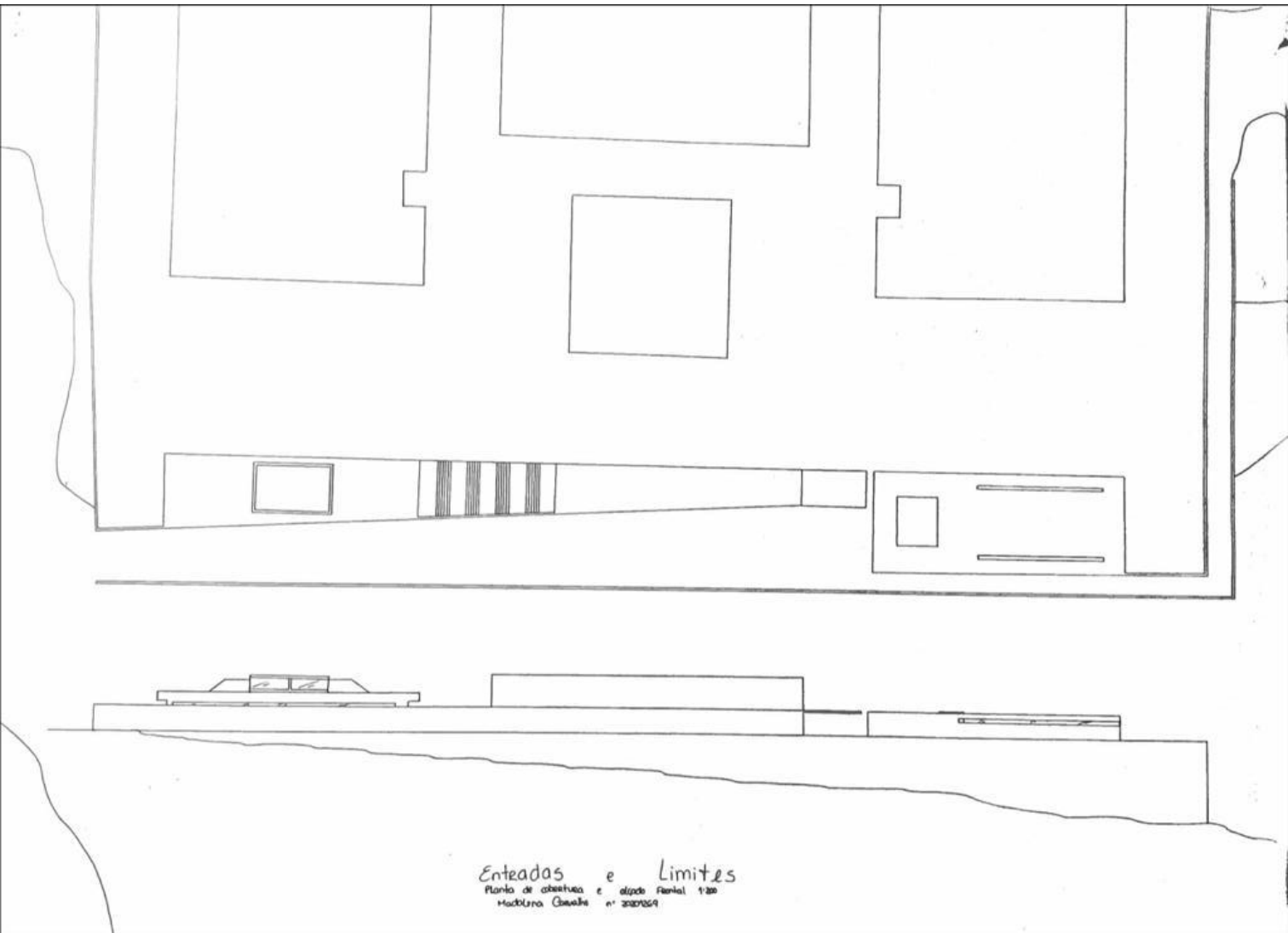

Planta articulada com Alçado Poente

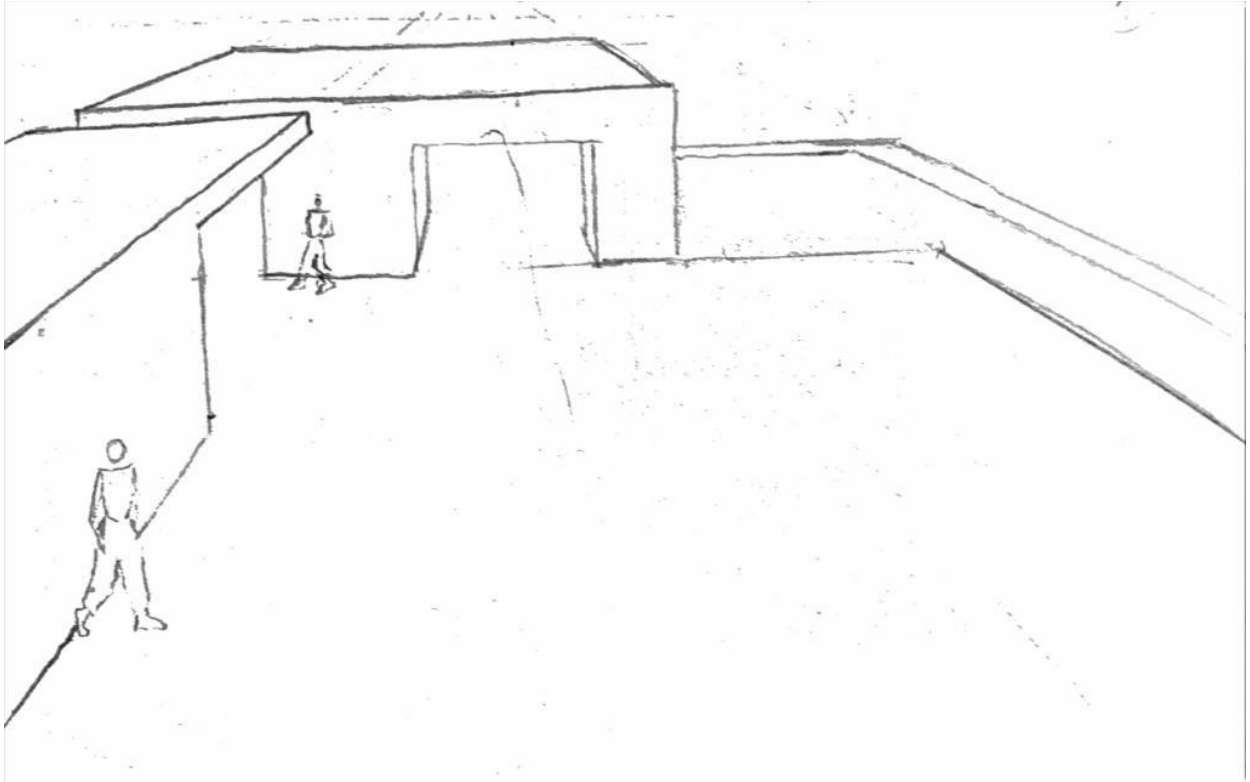

visão serial



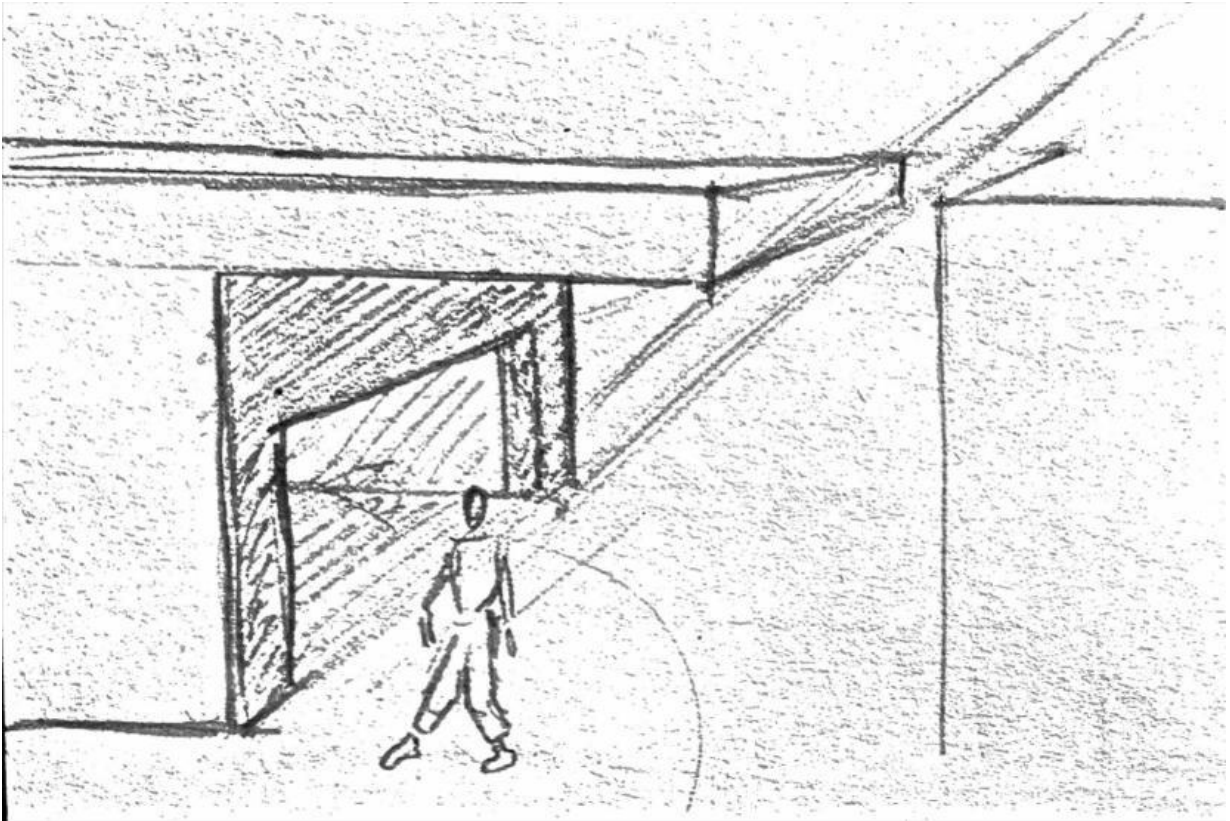

visão serial

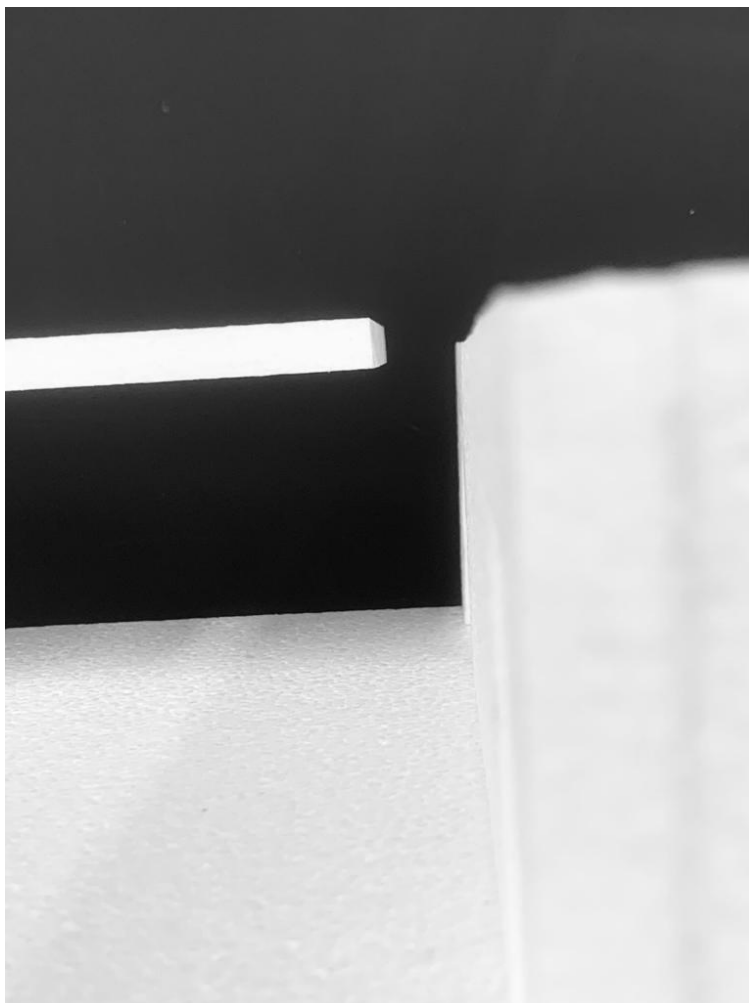

Maquete 1:50 detalhe

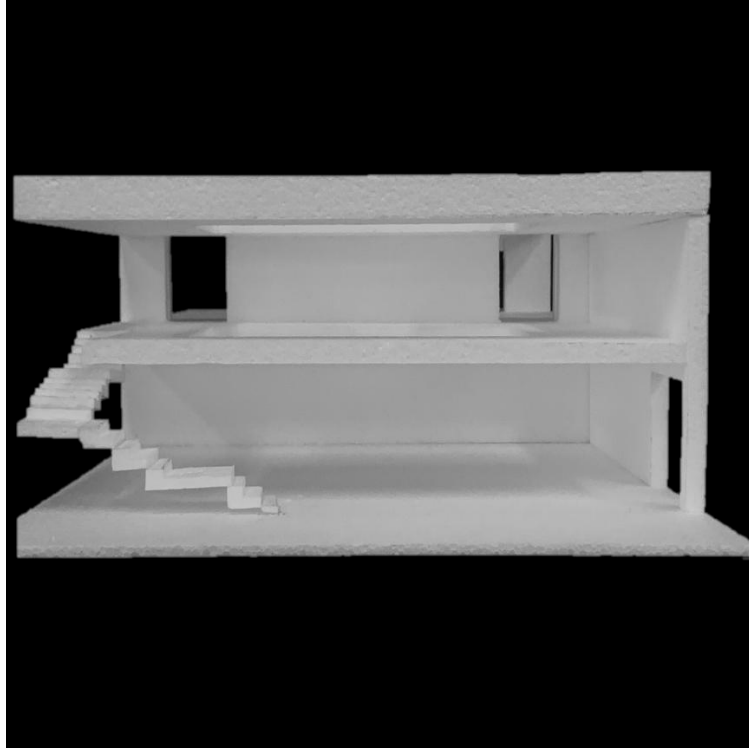

fotografias das maquetes de trabalho

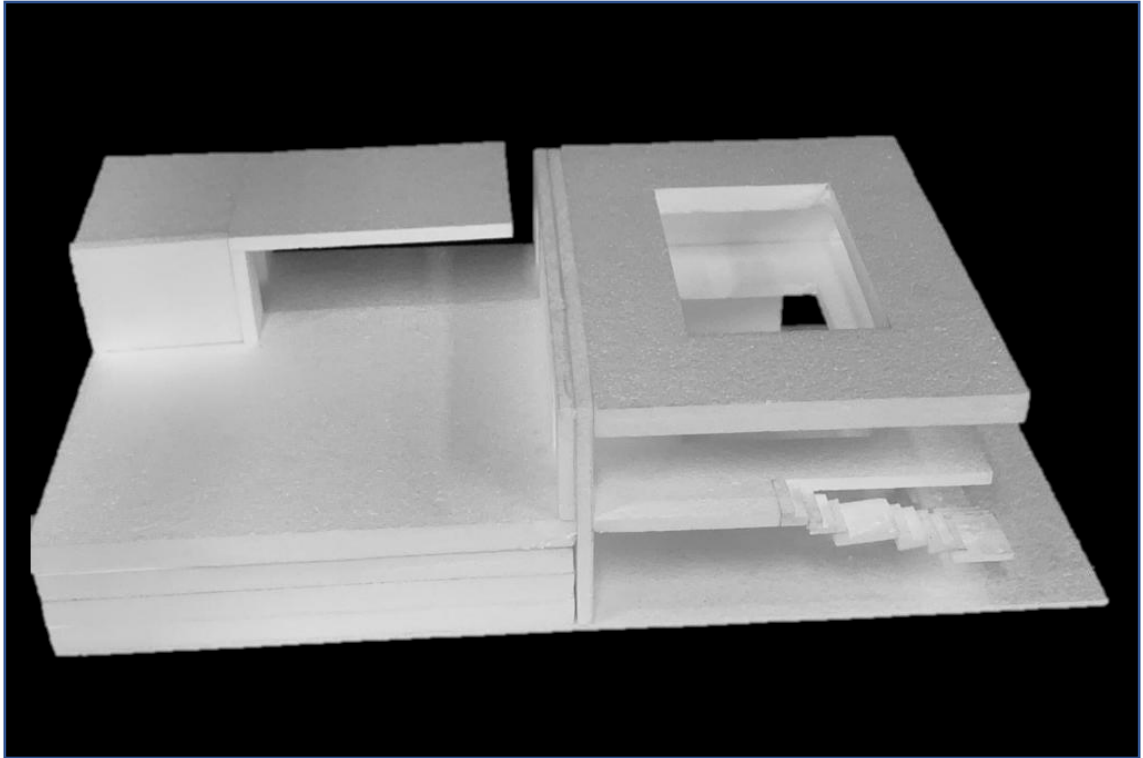

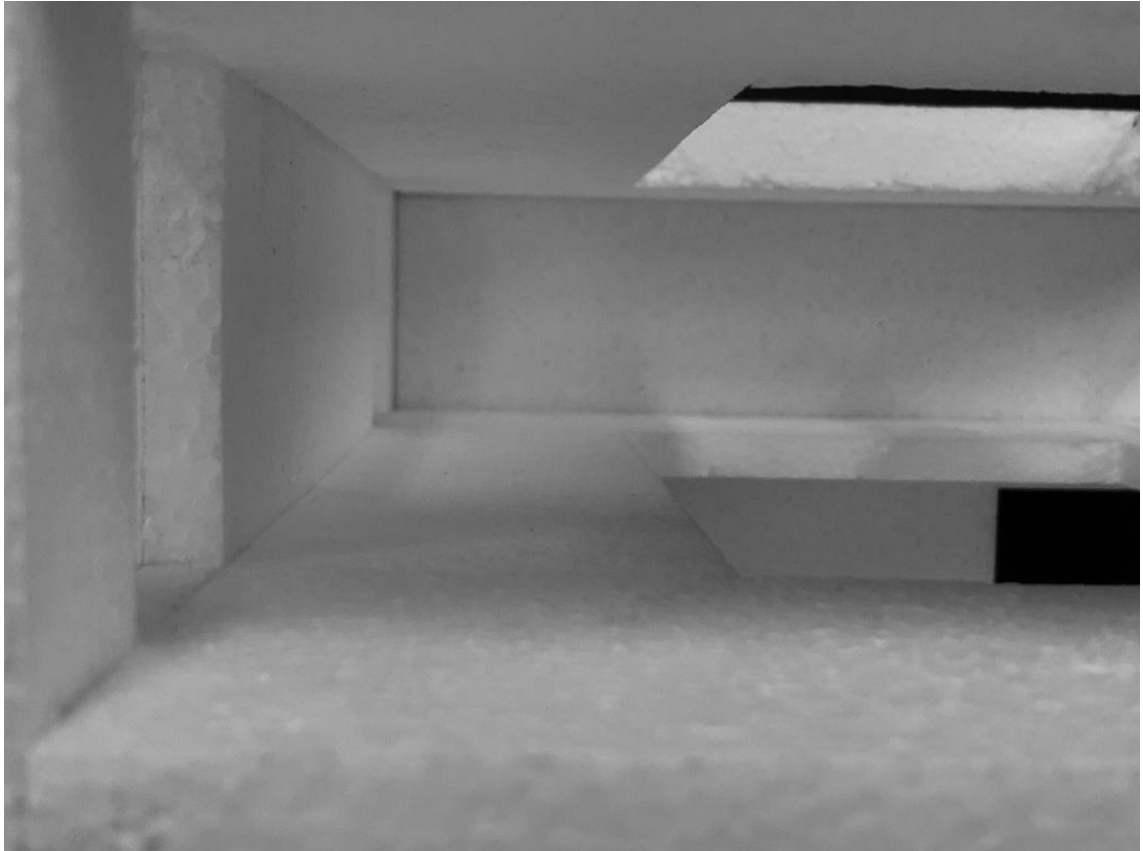



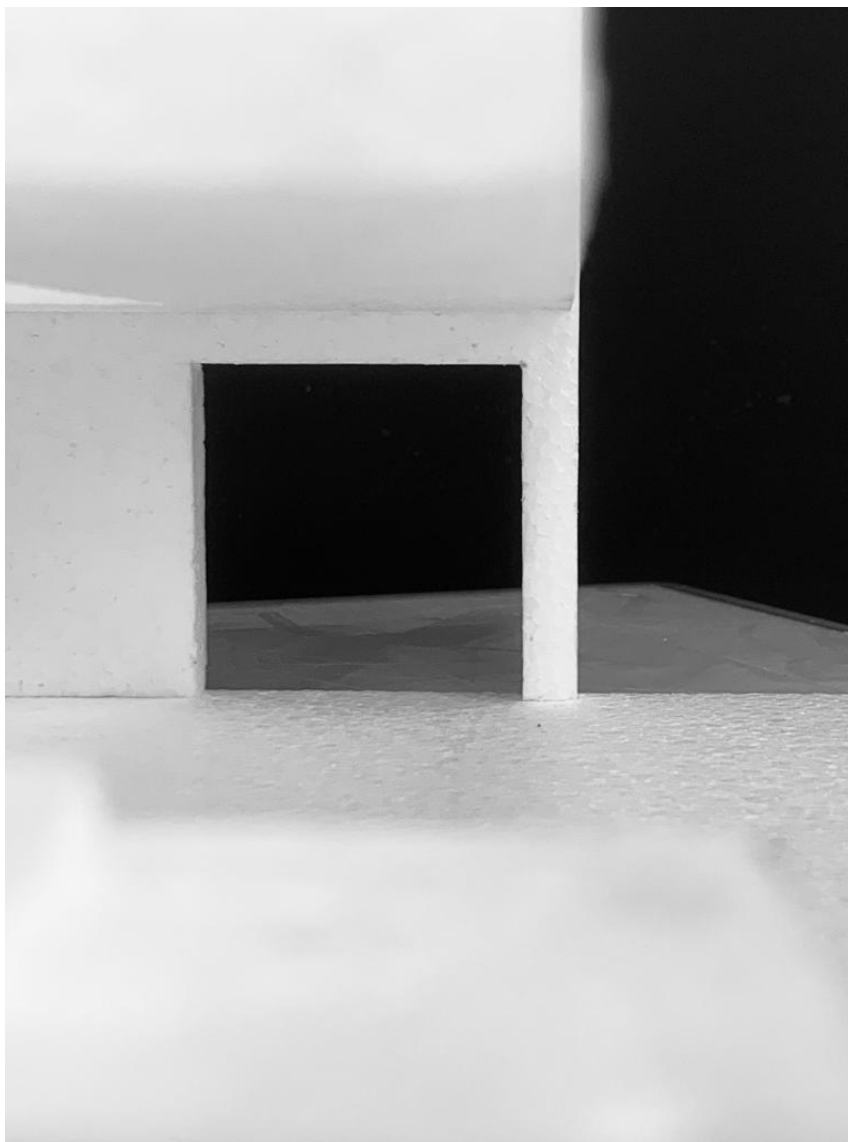





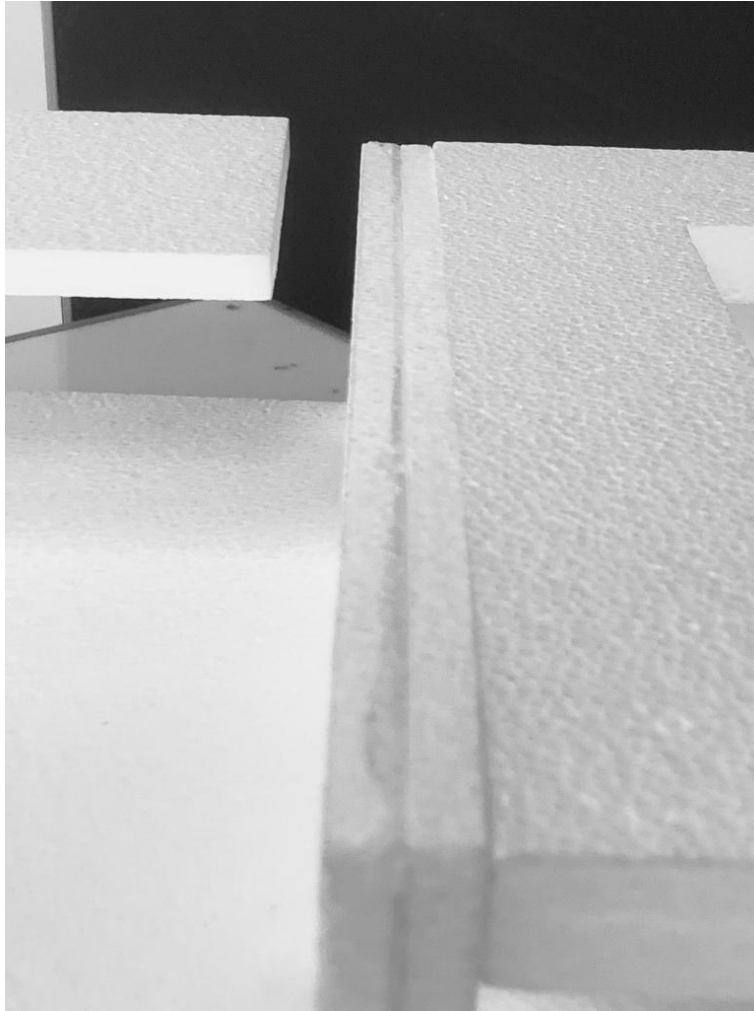



# 1ª fase

lado nascente

**Proposta**



World Trade Center Memorial, Michael Arad





Benesse House Museum, Tadao Ando

“If you’re lucky, and a building succeeds, the real product has many more dimensions than you can ever imagine. You have the sun, the light, the rain, the birds, the feel”

Peter Zumthor



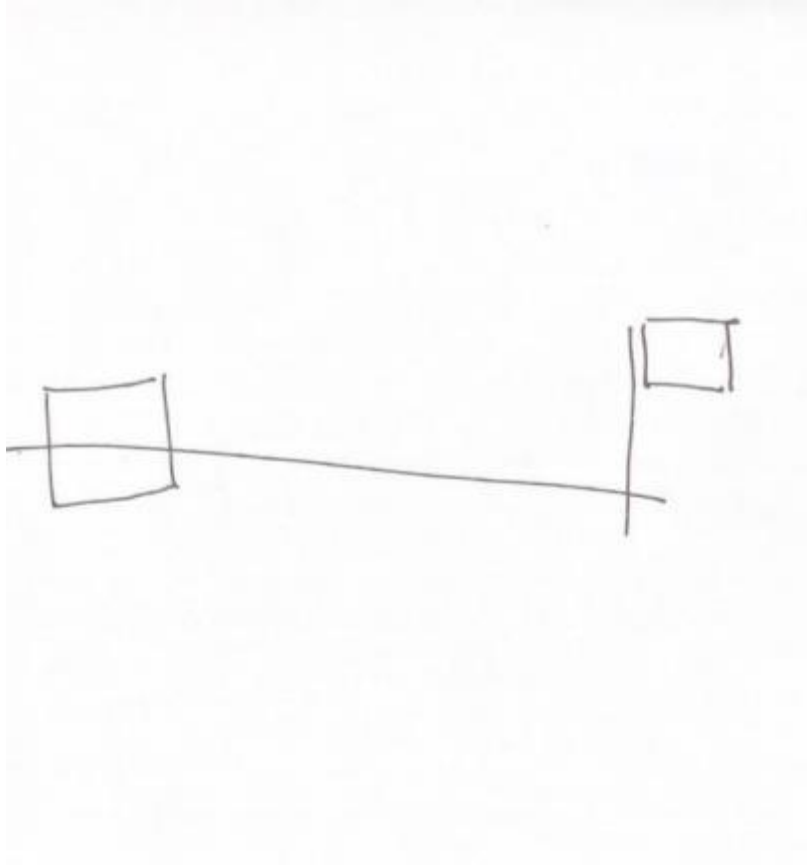

esquiço síntese





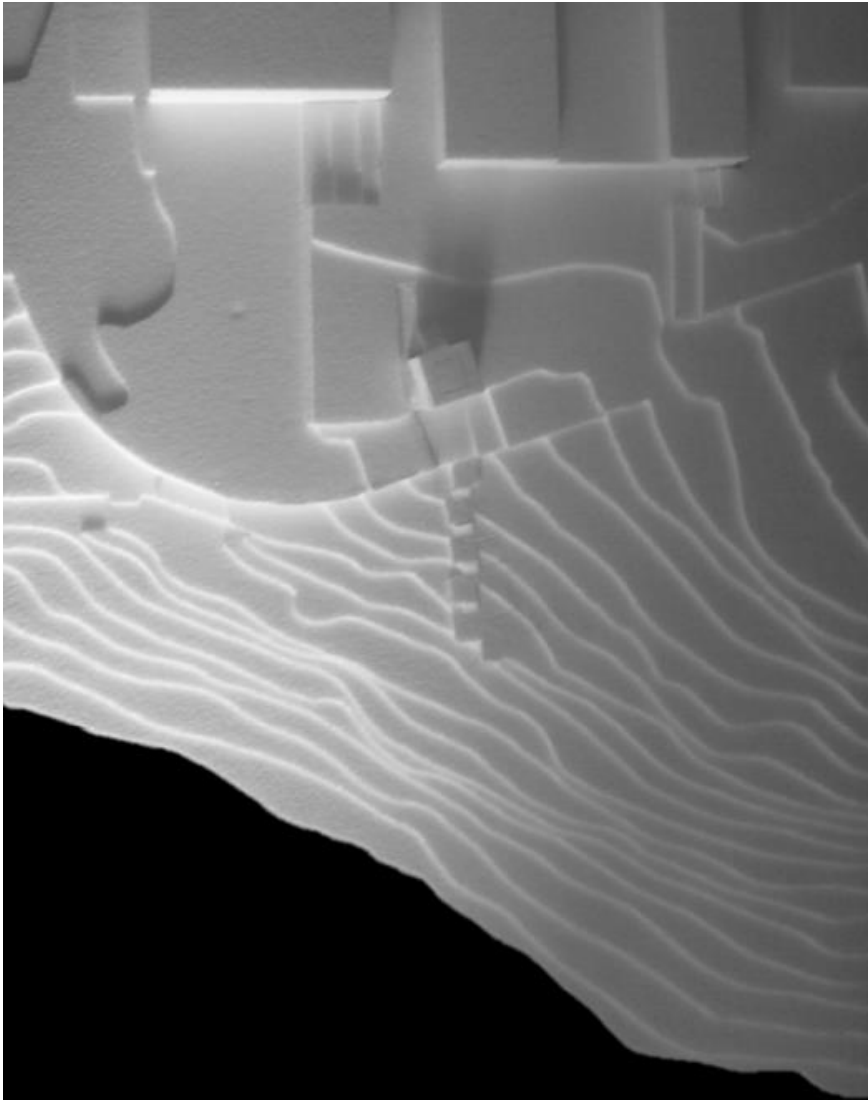

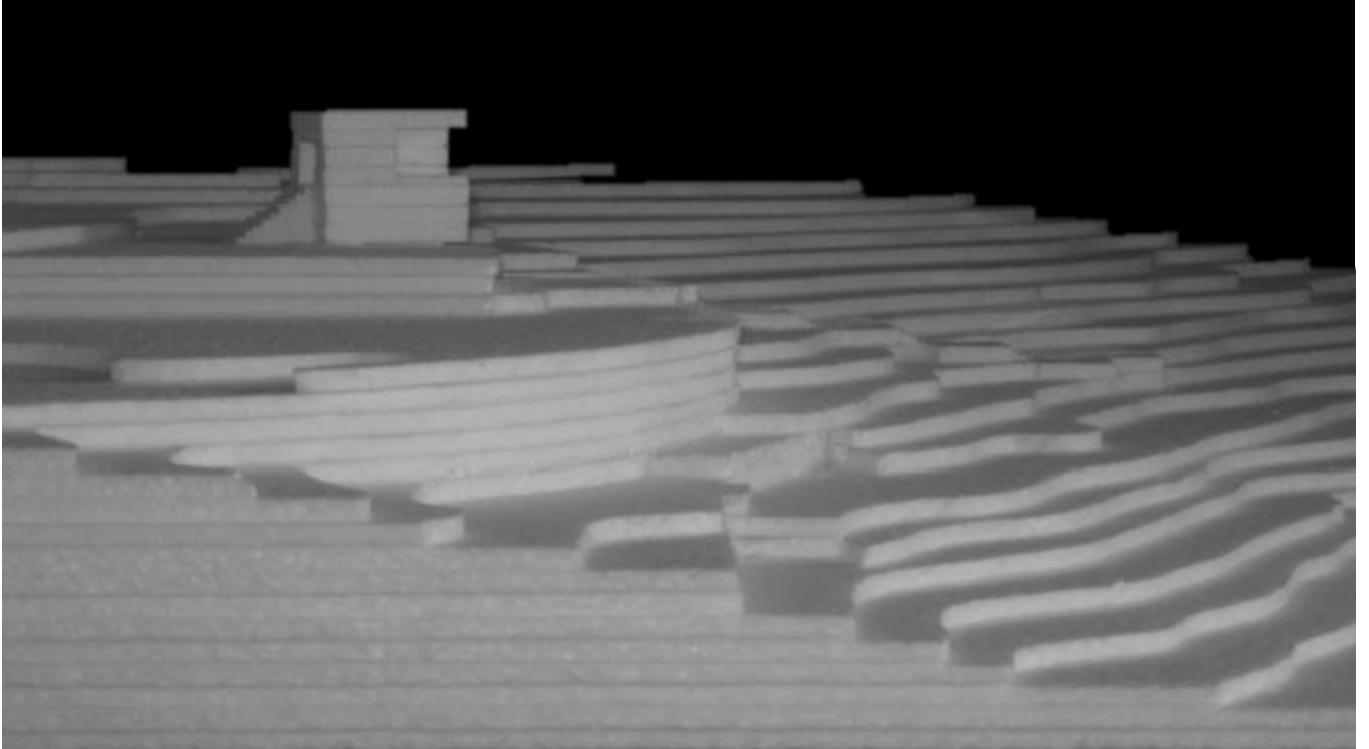

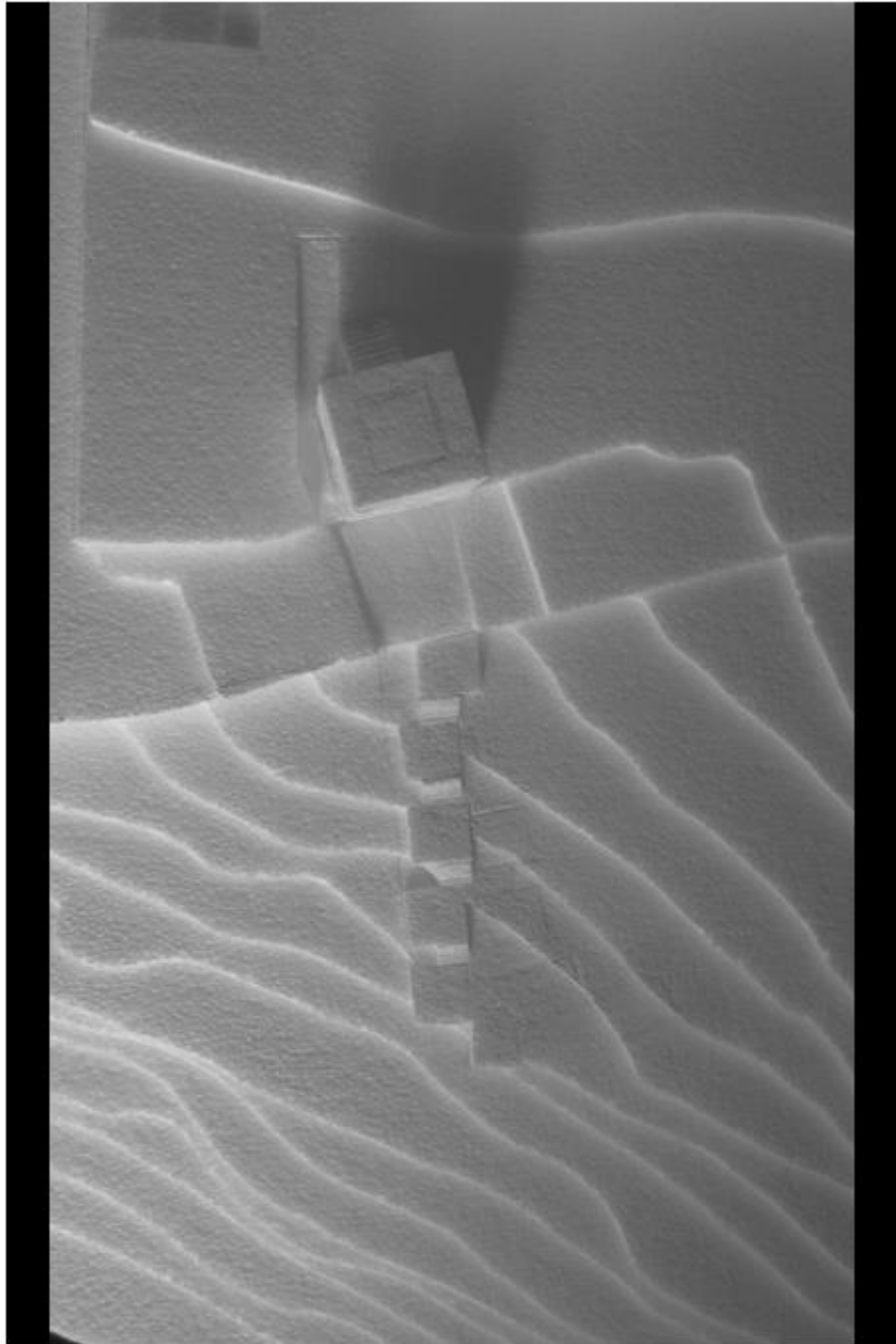

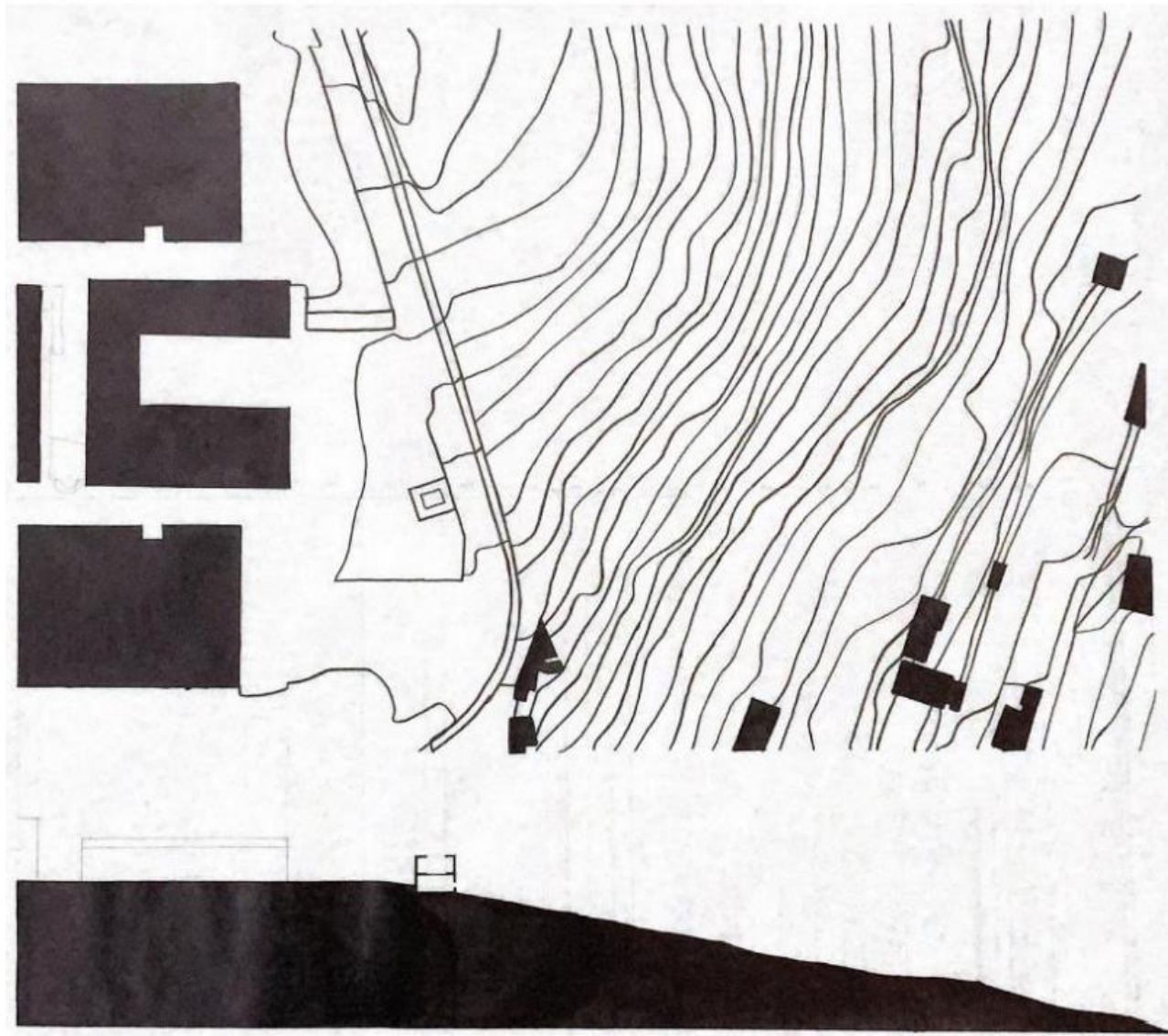

planta e perfil de conjunto



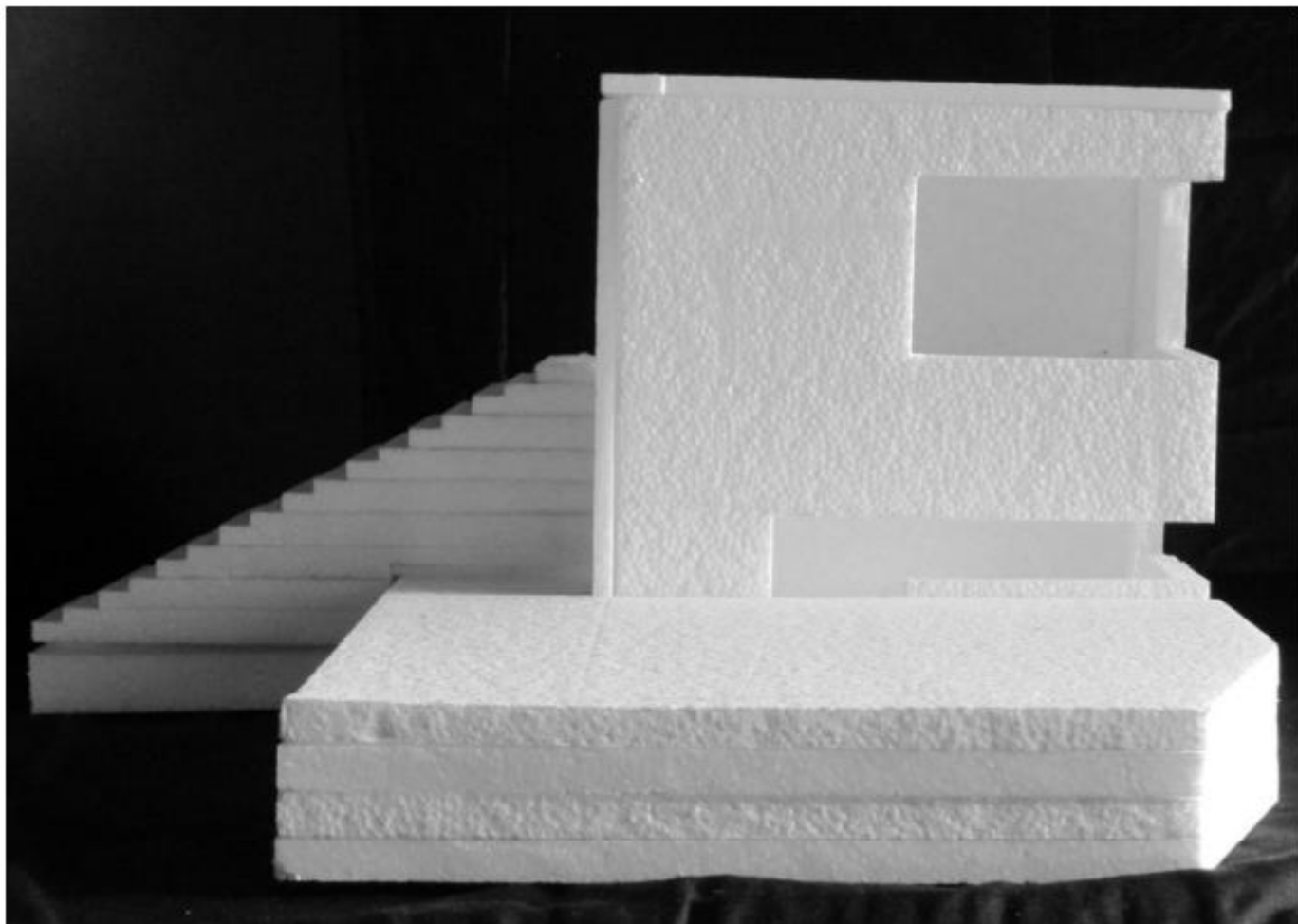



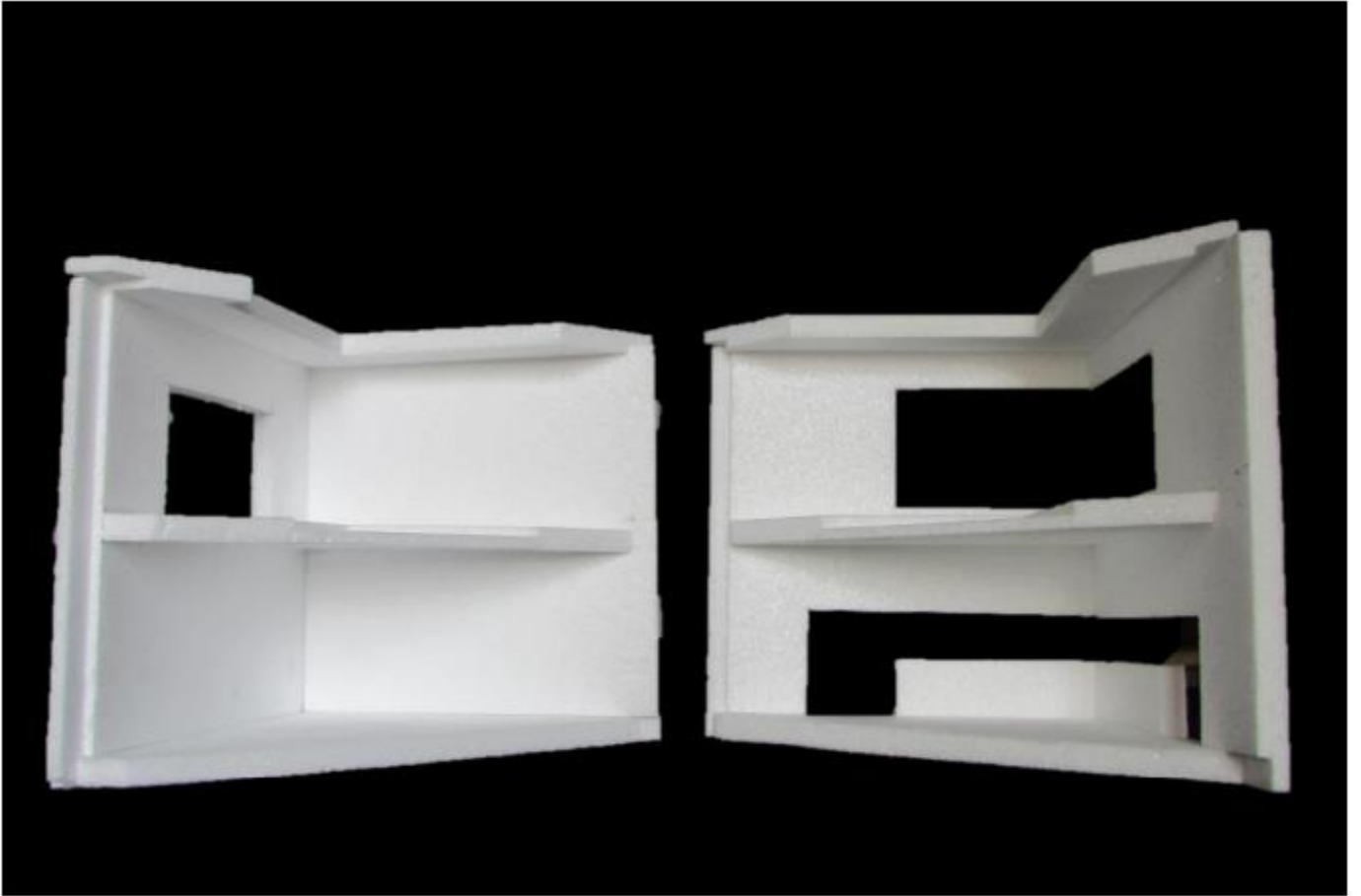

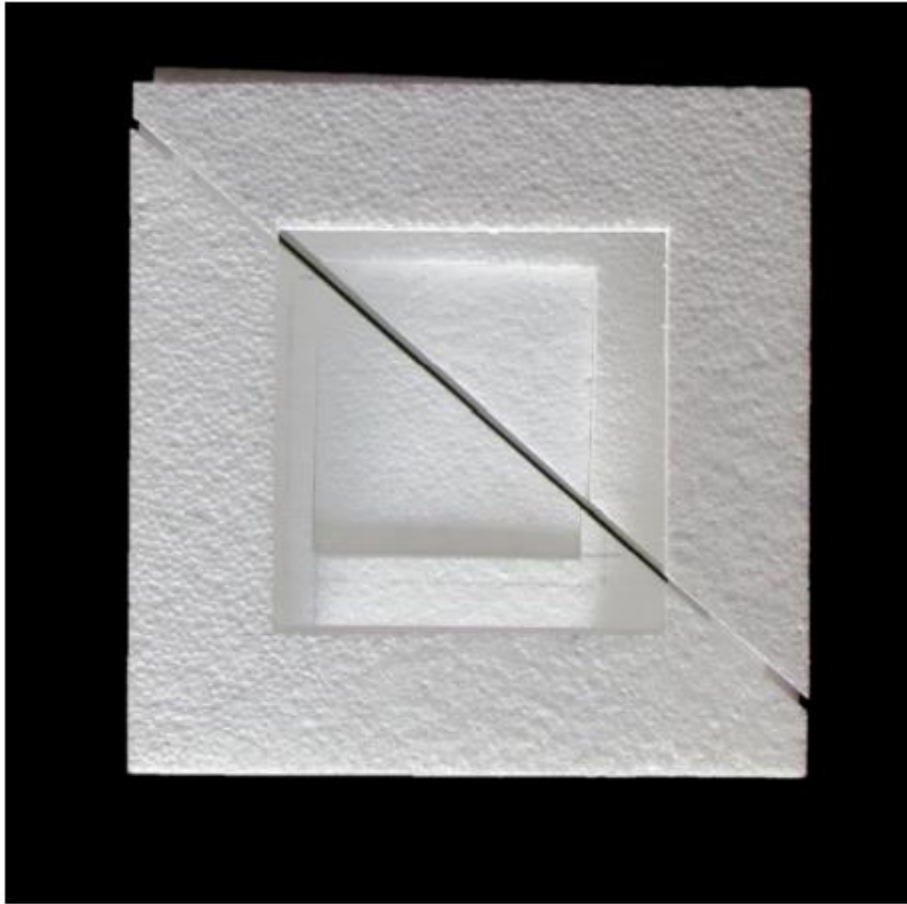



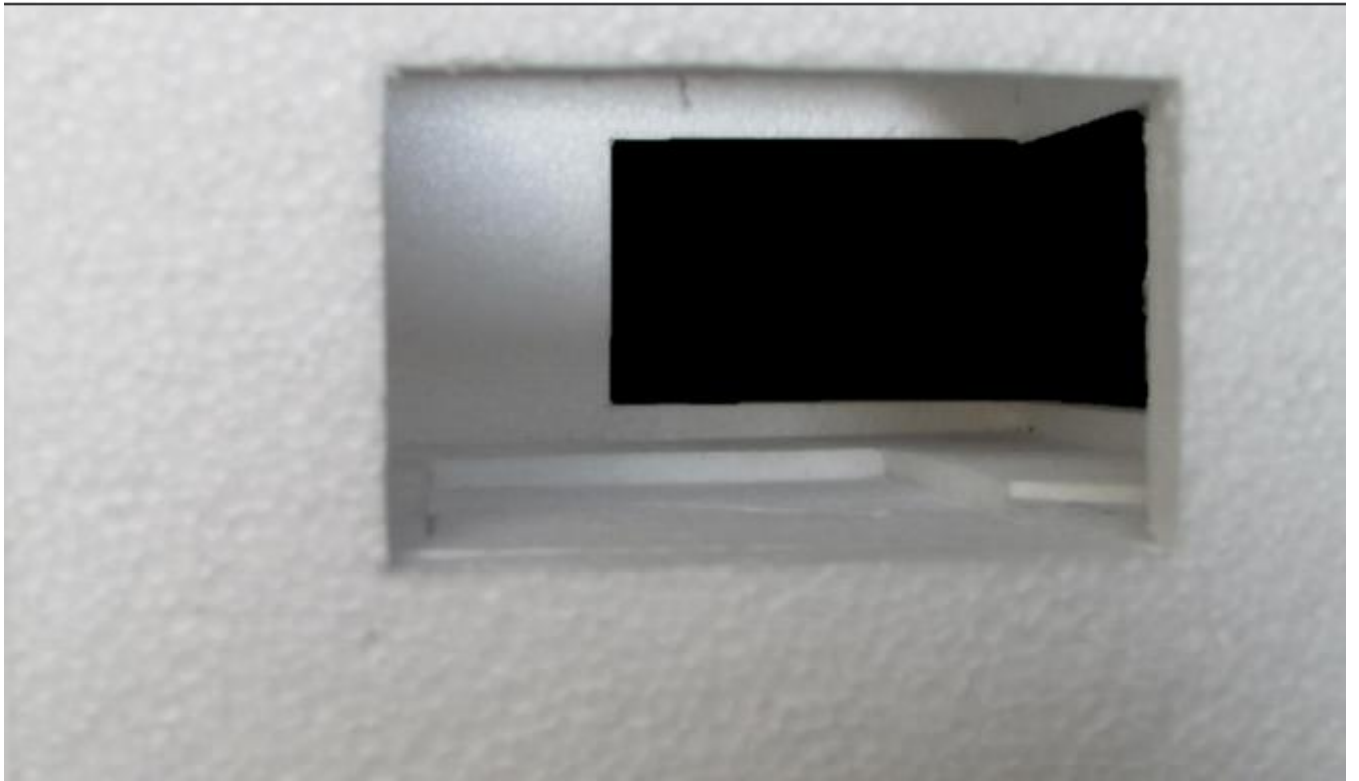

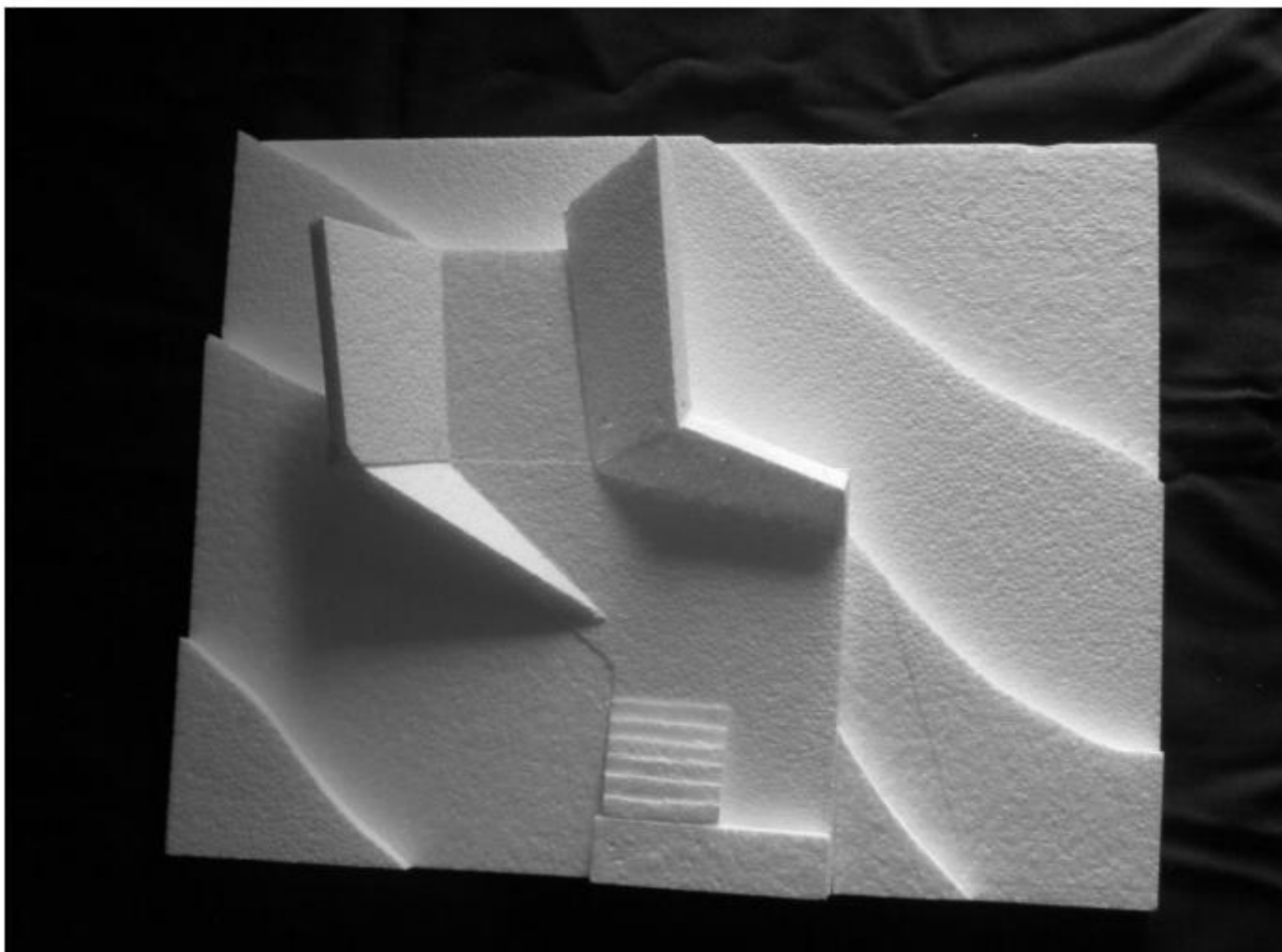

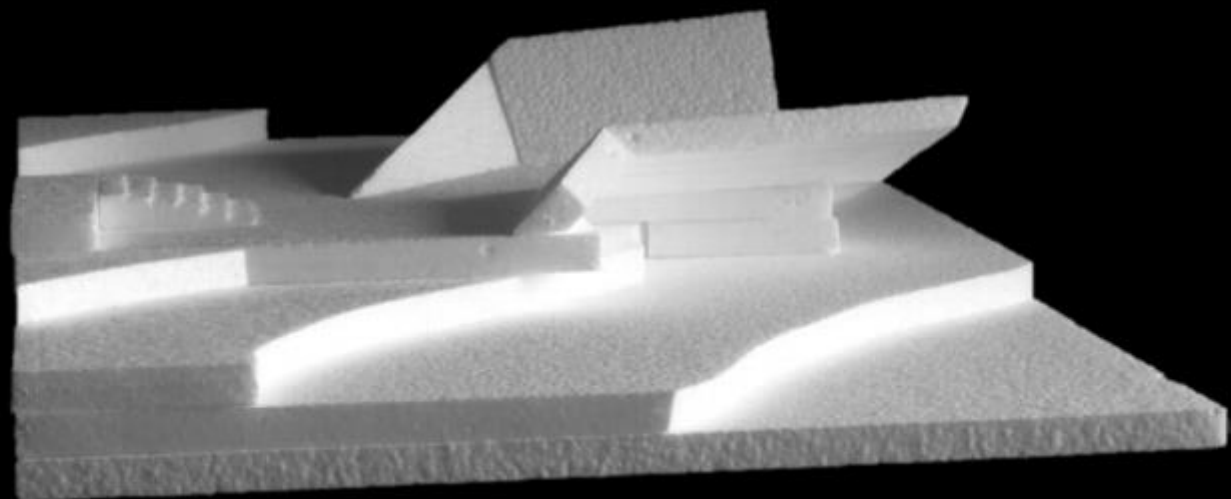



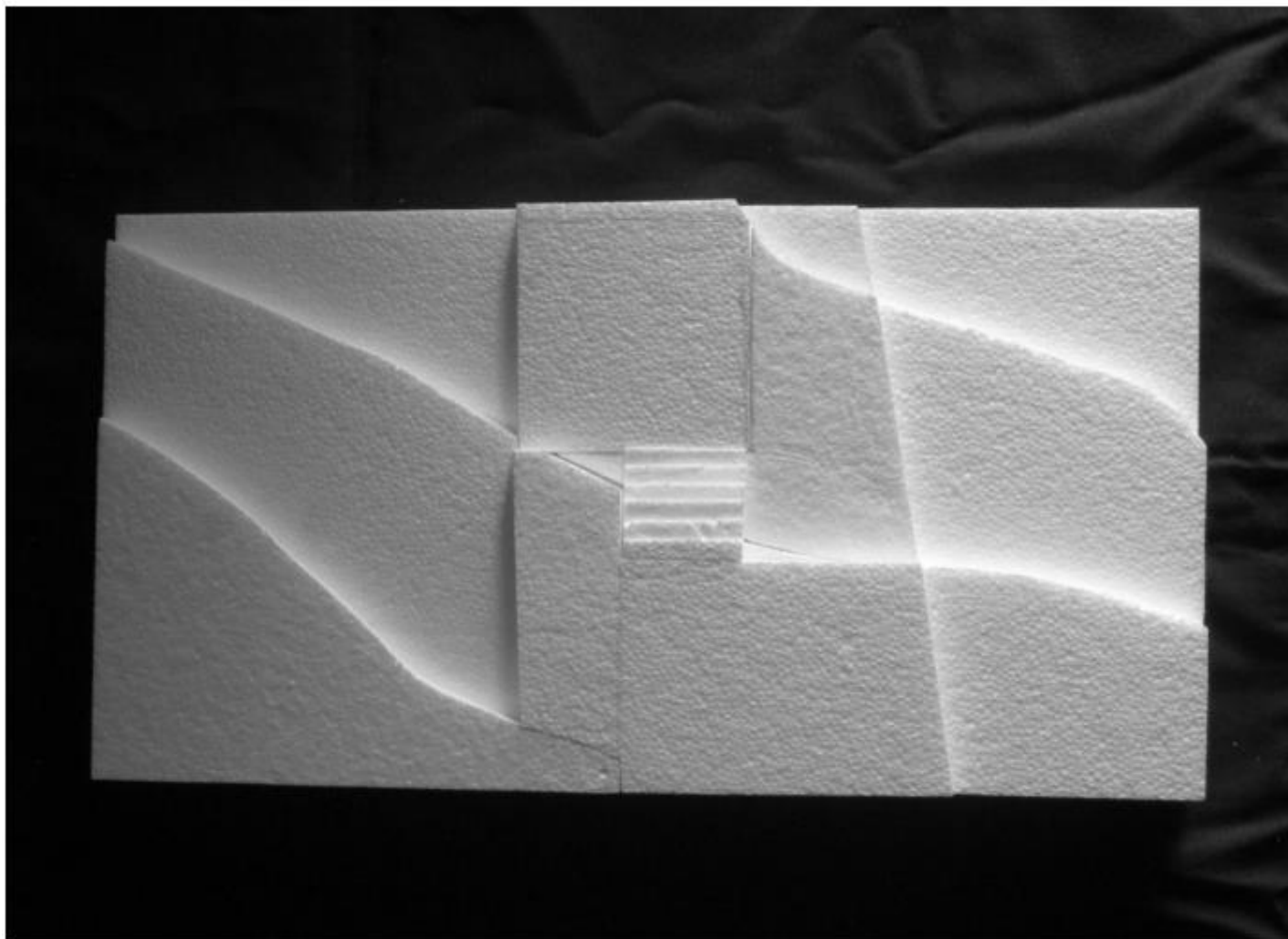

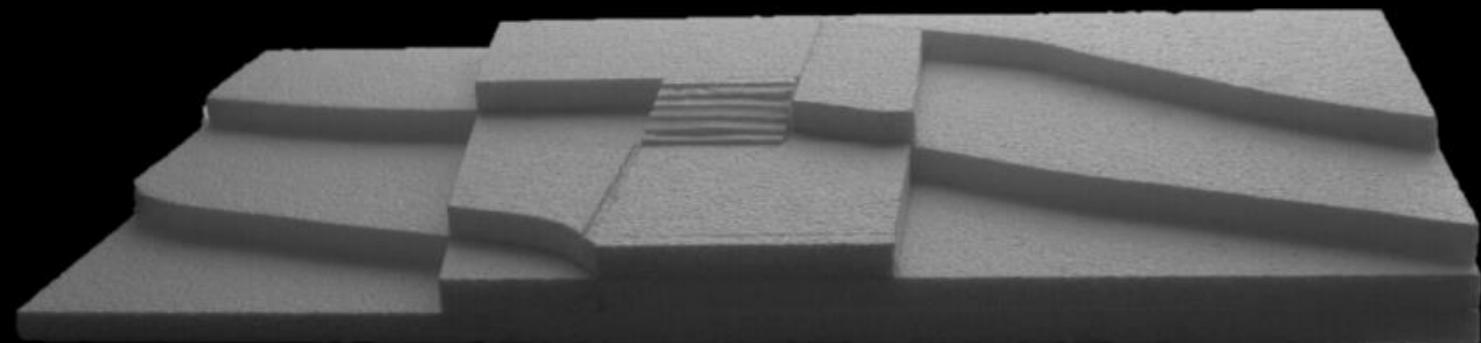







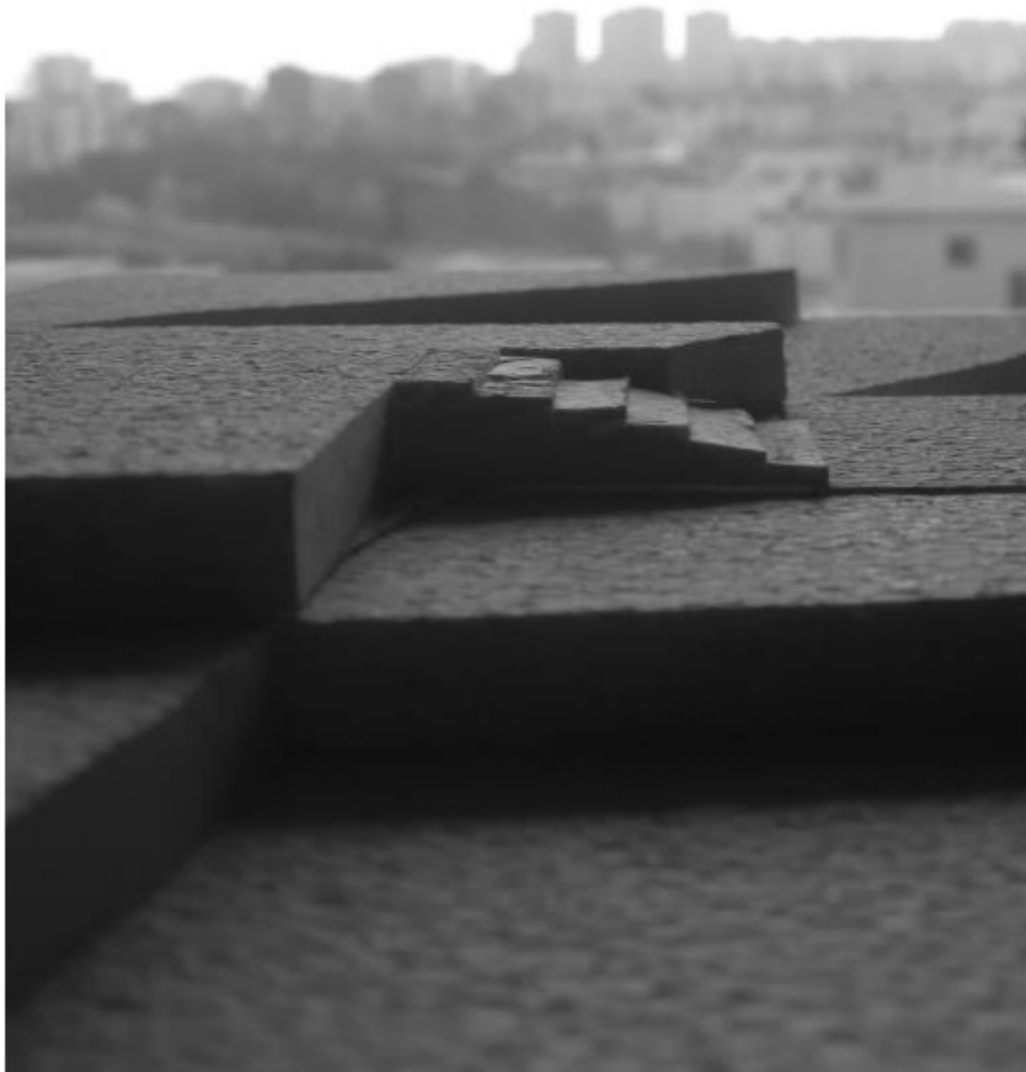

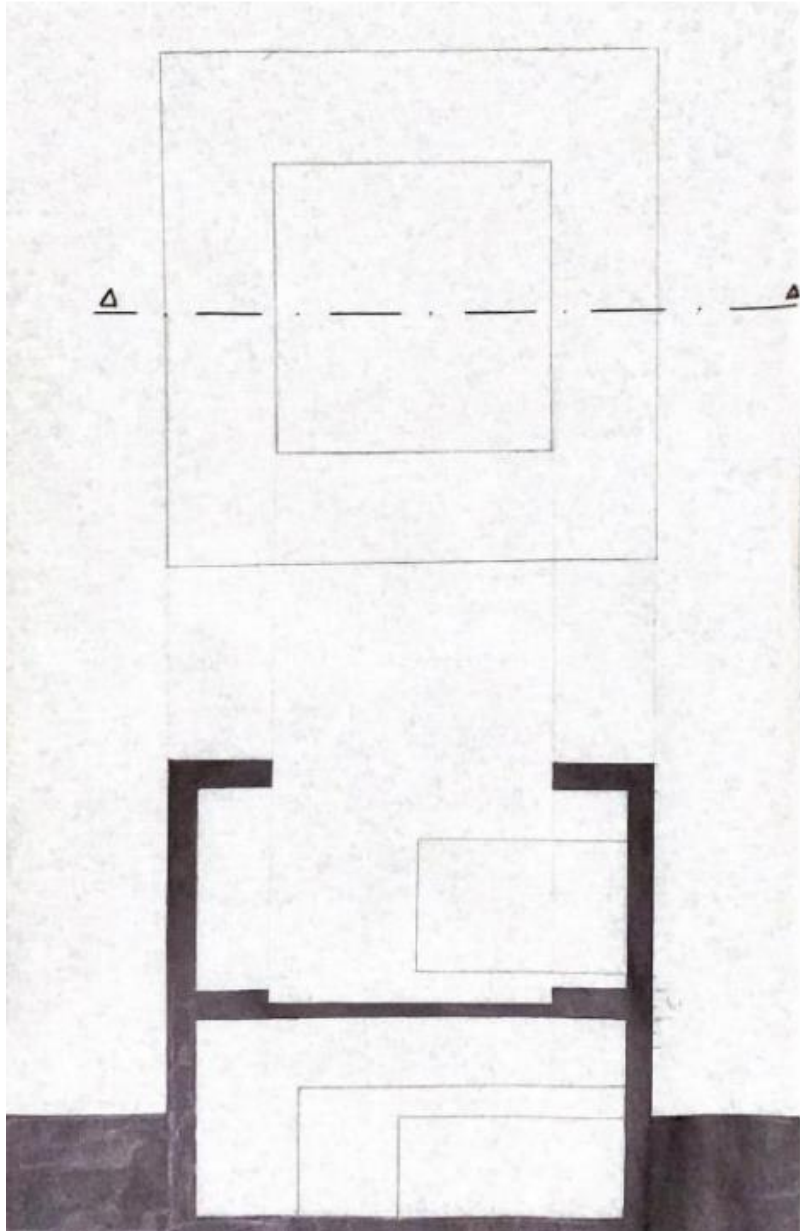

planta e corte

desenho(s) complementares

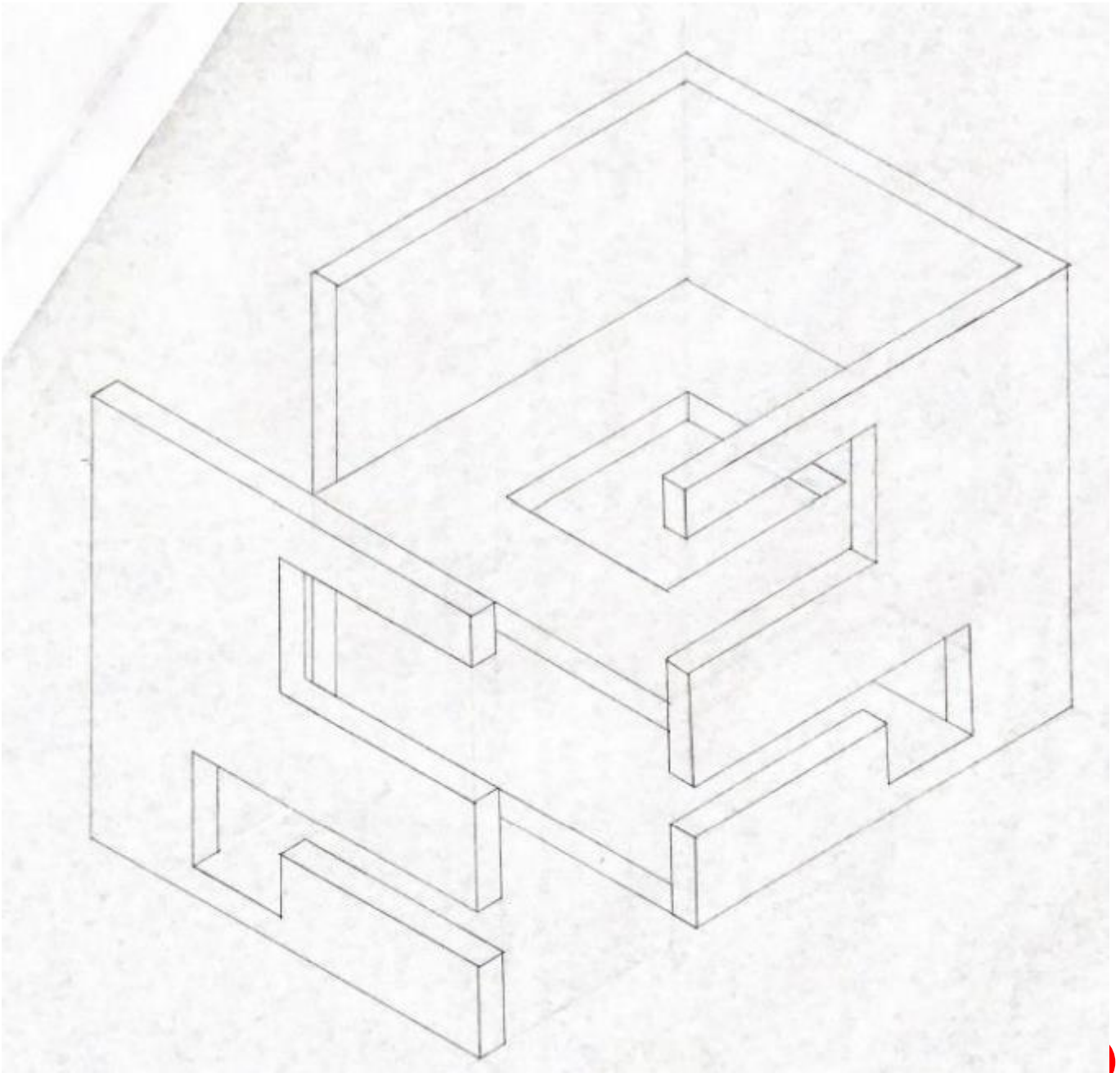

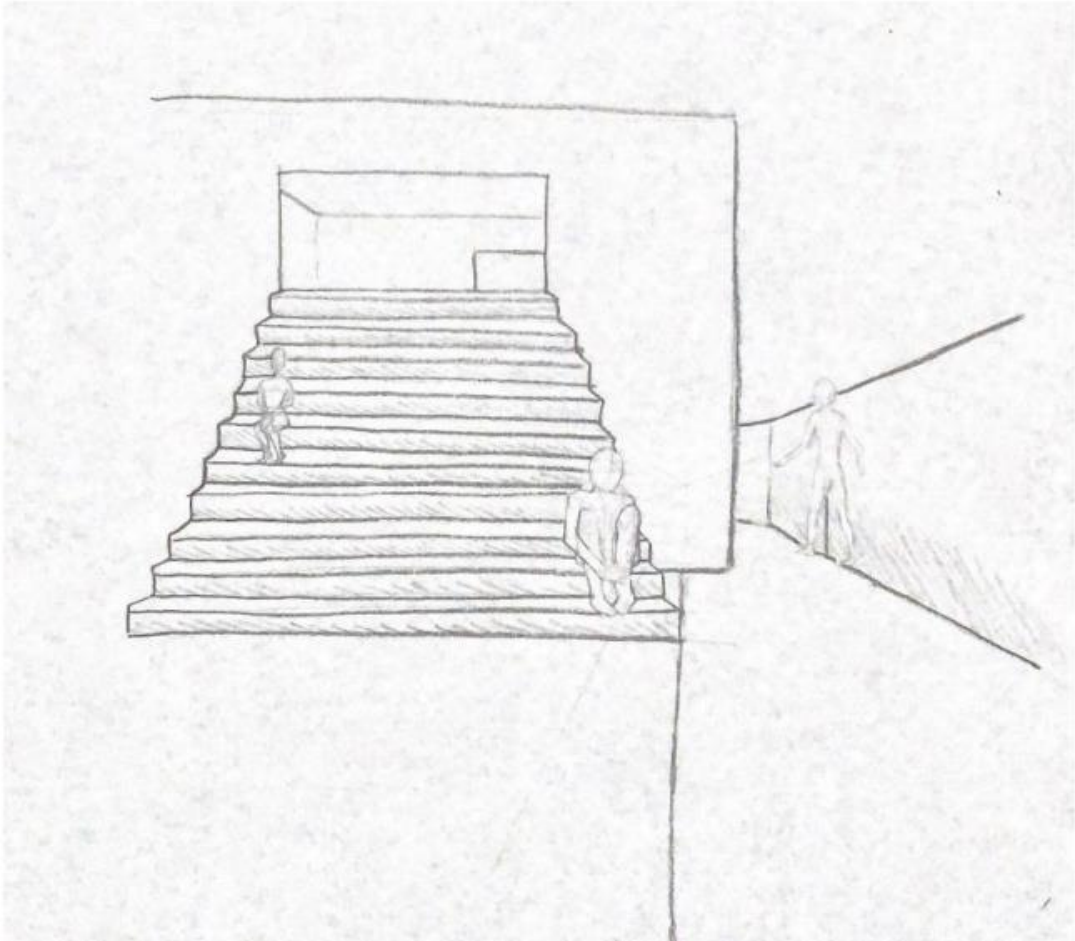

visão serial



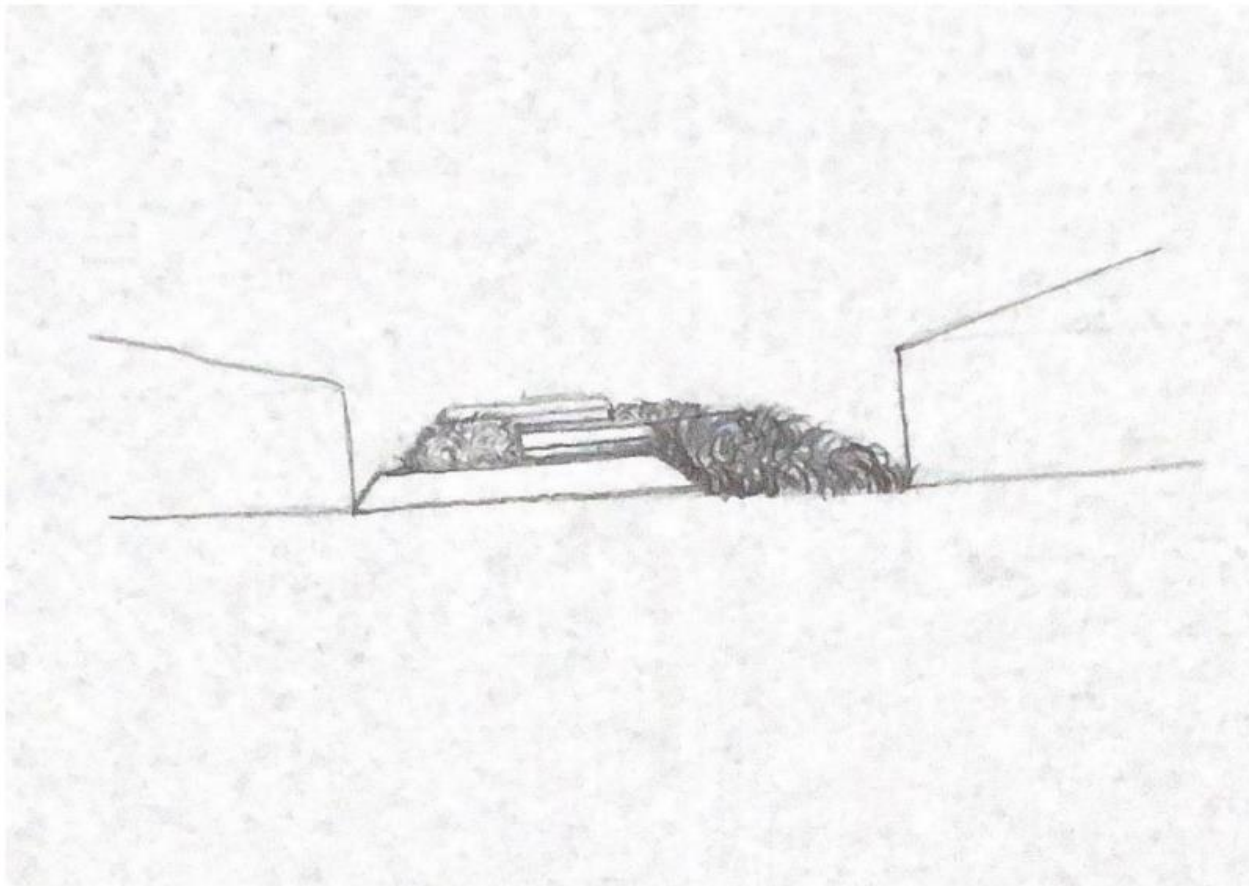

visão serial



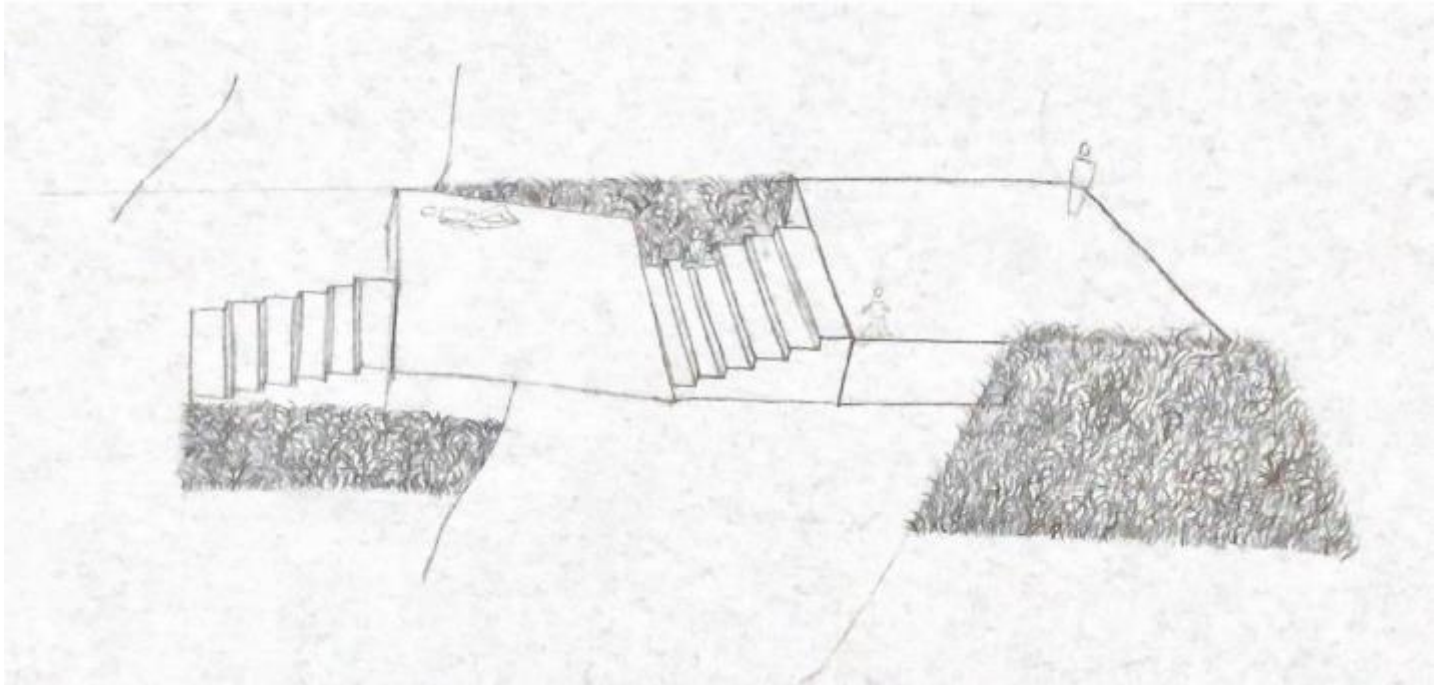

visão serial



**Processo**



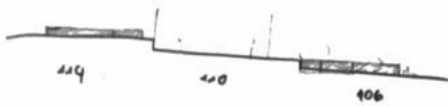

6 salas  
6 portões (faculdade)  
6 janelas  
6 espelhos separados  
Relação com a  
Faculdade (as  
salas  
'aberm-se')

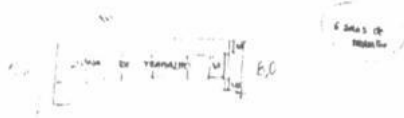

Voto as  
aberturas X  
- vista 360°  
- efeito altura  
- que a chova e  
o vento  
insustentável  
to piso

Paredes de  
'velho' e  
'a reabertura?

meio  
aberto  
(afundado?)



Alçado (Frontal)



largo de abertura  
(vista para a  
estrada)

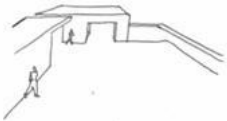
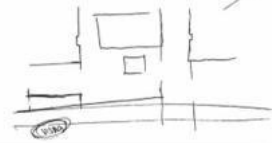

→ PROMENADE  
ARCHITETURALE

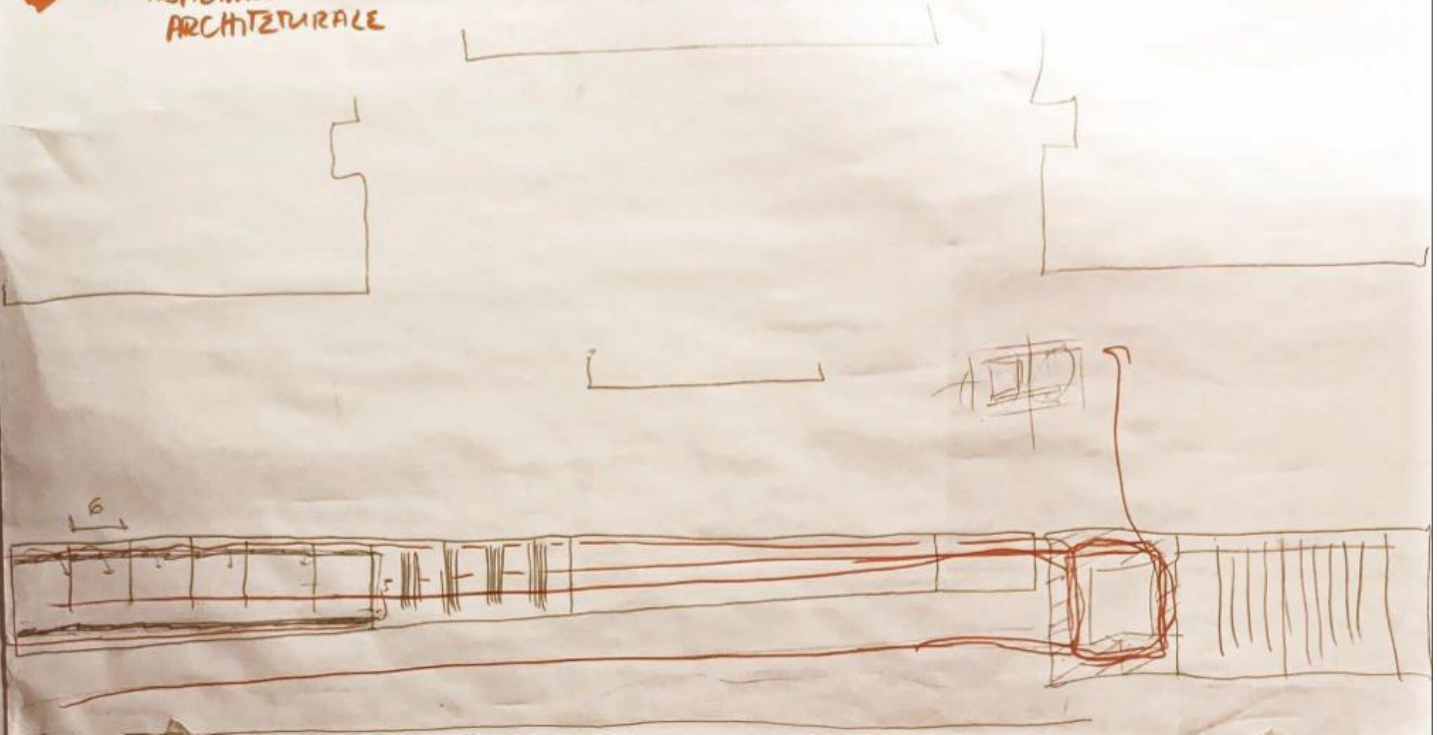

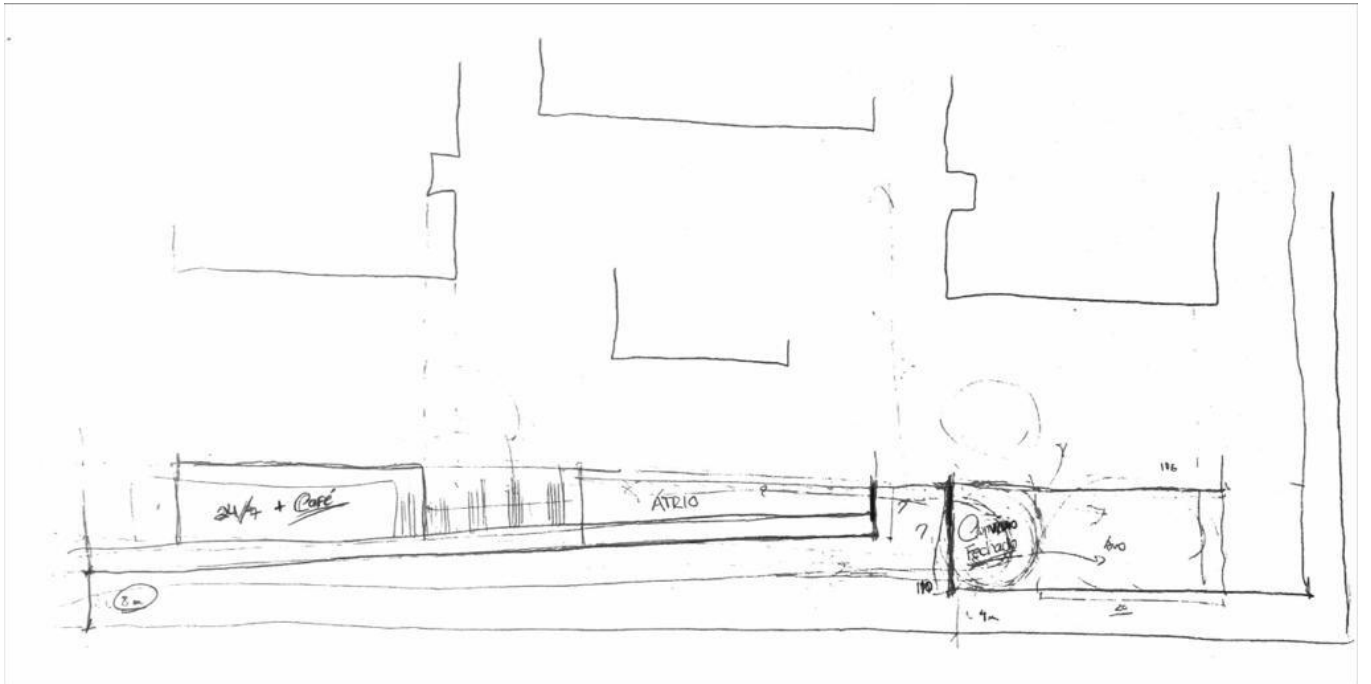

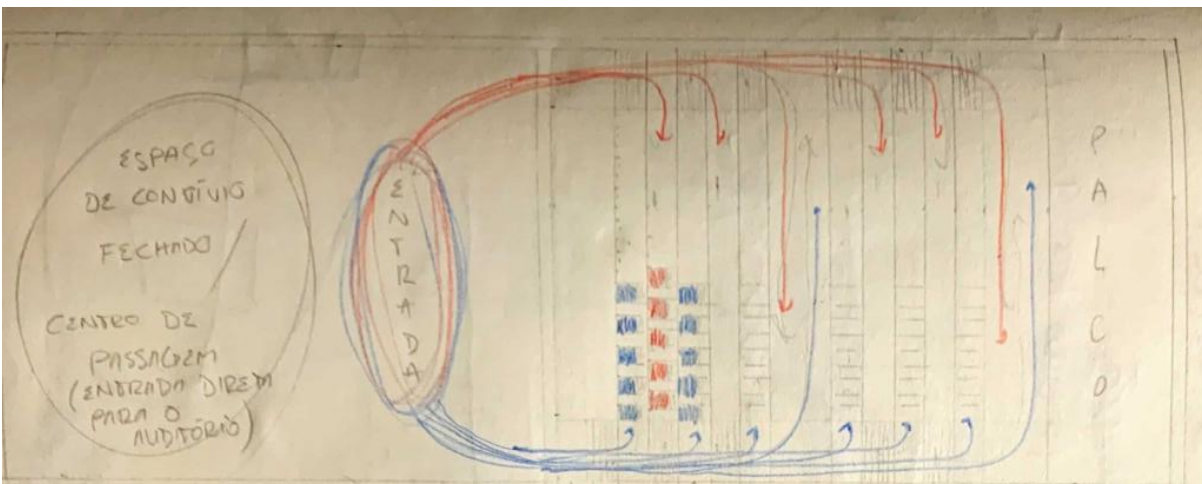

QUAL O GRAU DE INCLINAÇÃO?

- 30%
- 15%

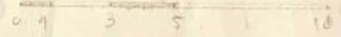

OUTRA ENTRADA  
 CATEGORIA SILE  
 DIREÇÃO PARA O INTERIO  
 PESSOAS QUE VÊM DE BARRIO (740)

- PAREDE  
 - TUBERIA  
 - TUBERIA  
 - TUBERIA

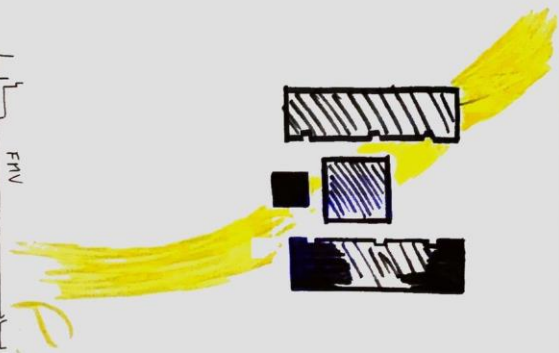
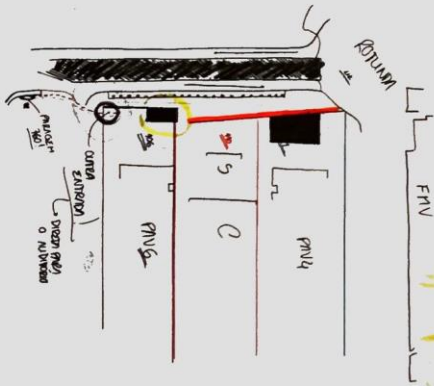

PLACA 109



RAMPA → 114 / 110 (109)

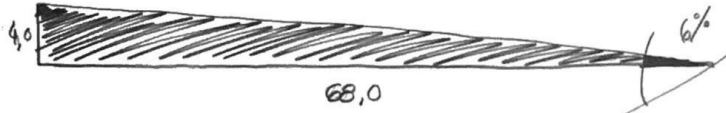

ENTRADA DI FUL

IDEN

EXCERCIAMENTOS DE  
TERMINAIS PARA  
ENTRADA

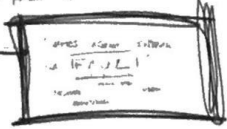

ENTRADA  
ENFASE

RELATÓRIO  
1º EXERCÍCIO

Paralelo da  
rua de 1/100m  
1 - Inclinado  
2 - Plano horizontal  
3 - Plano inclinado  
4 - Plano vertical  
5 - Plano horizontal  
6 - Plano inclinado  
7 - Plano vertical

SECRETARIA

ESPAÇOS

LABE - ~~LABE~~  
ESPLANADA

LABE → 21/7

LABE → ALVARÉO

LABE → 20/10/10

LABE → ALVARÉO  
ALVARÉO (10/10/10)

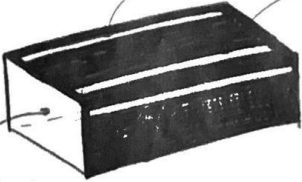

ENTRADA

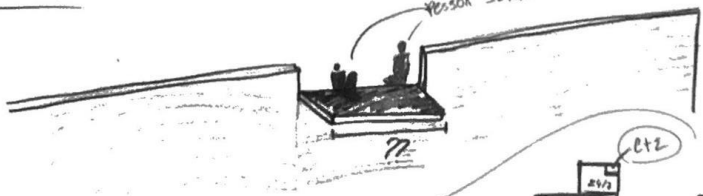

FRAGMENTAÇÃO DO  
MEIO → ESPAÇOS  
DE CONVÍVIO AO  
AR LIVRE



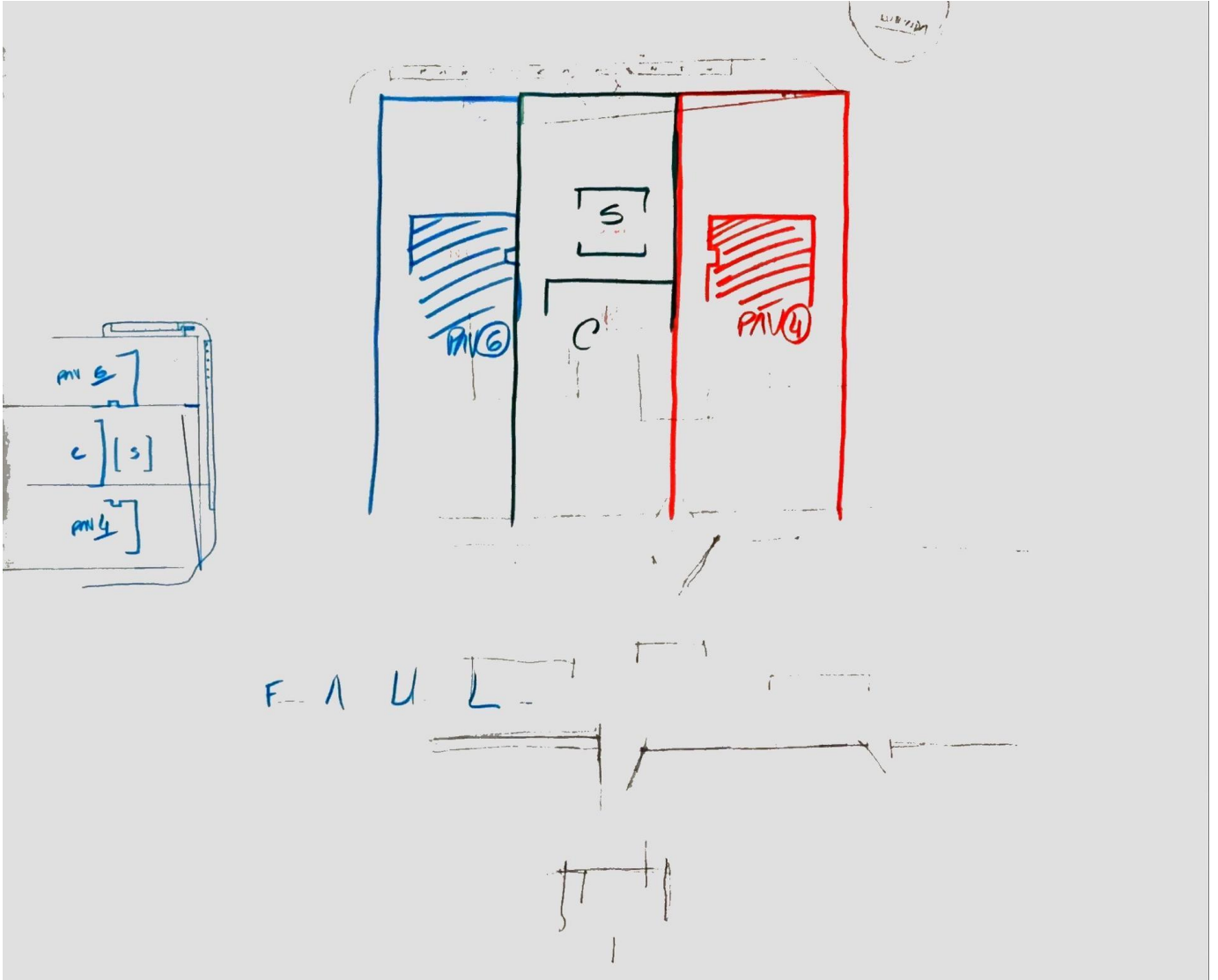





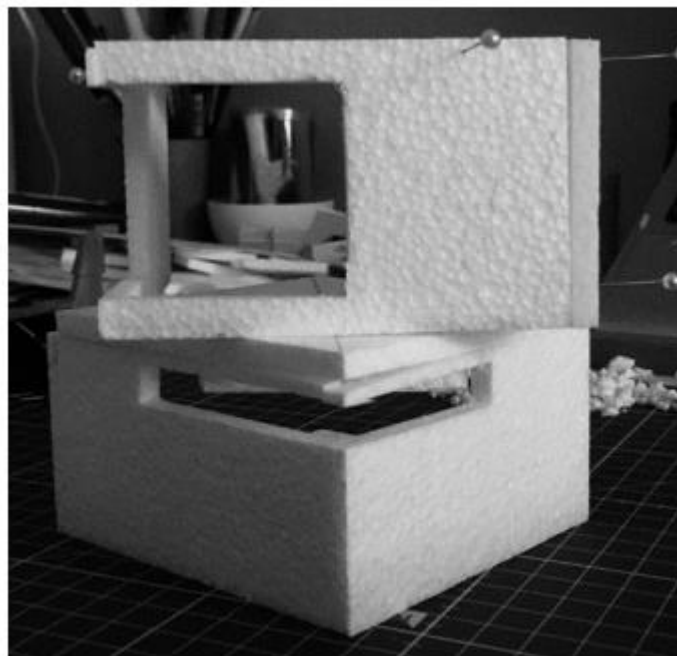
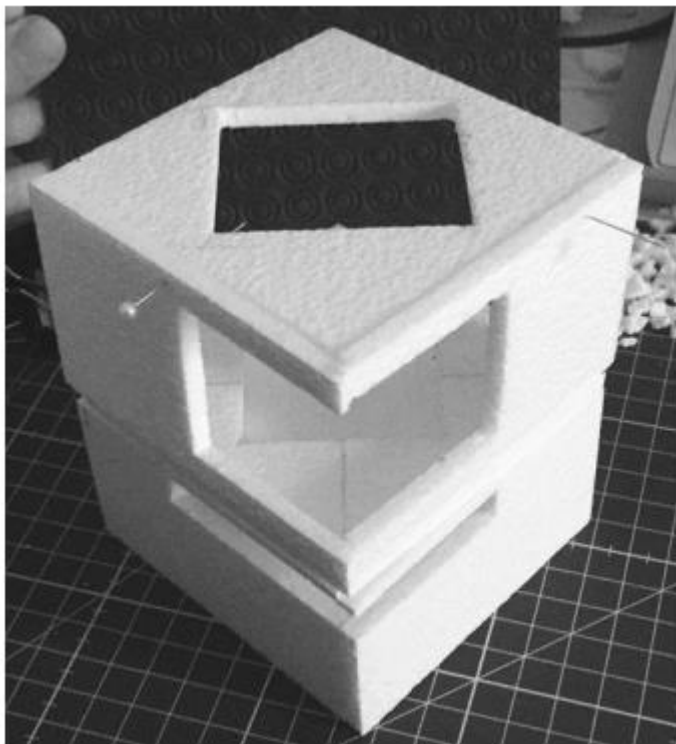
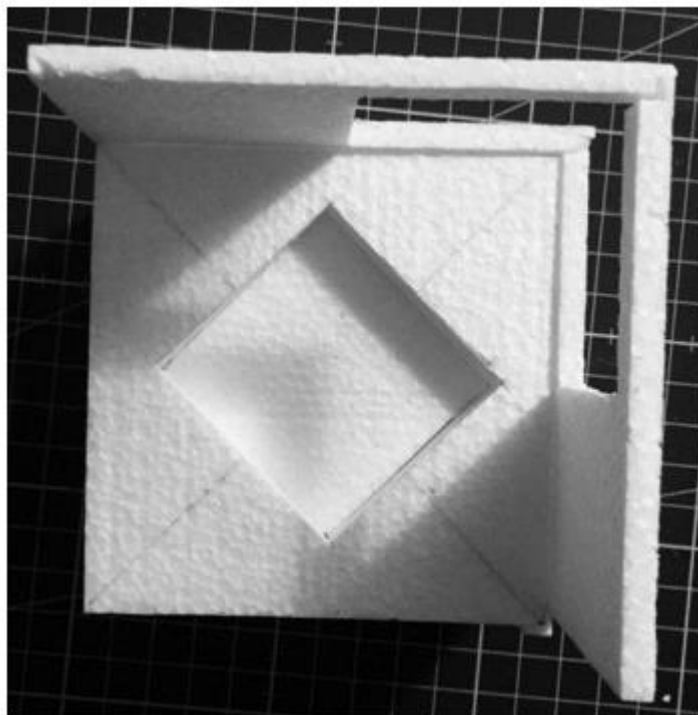
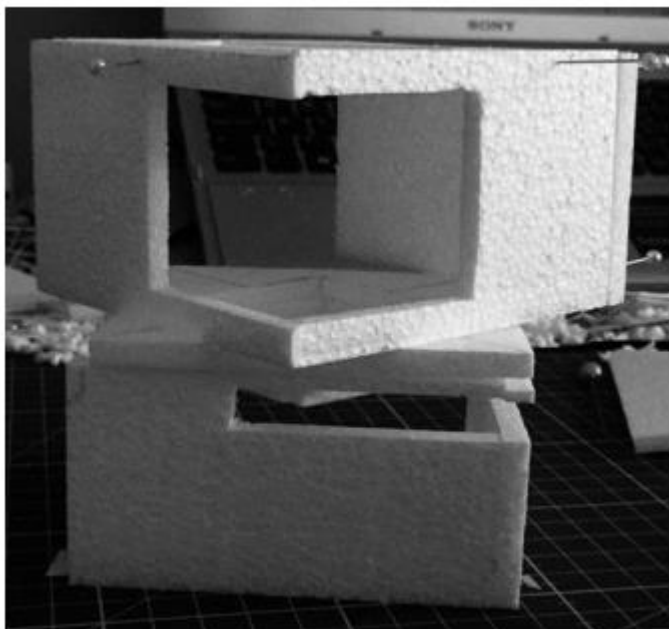

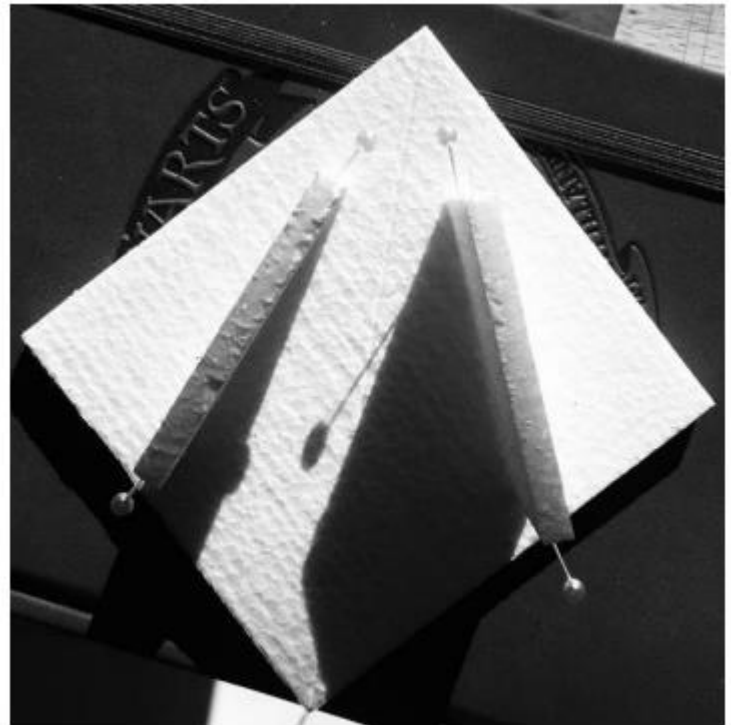
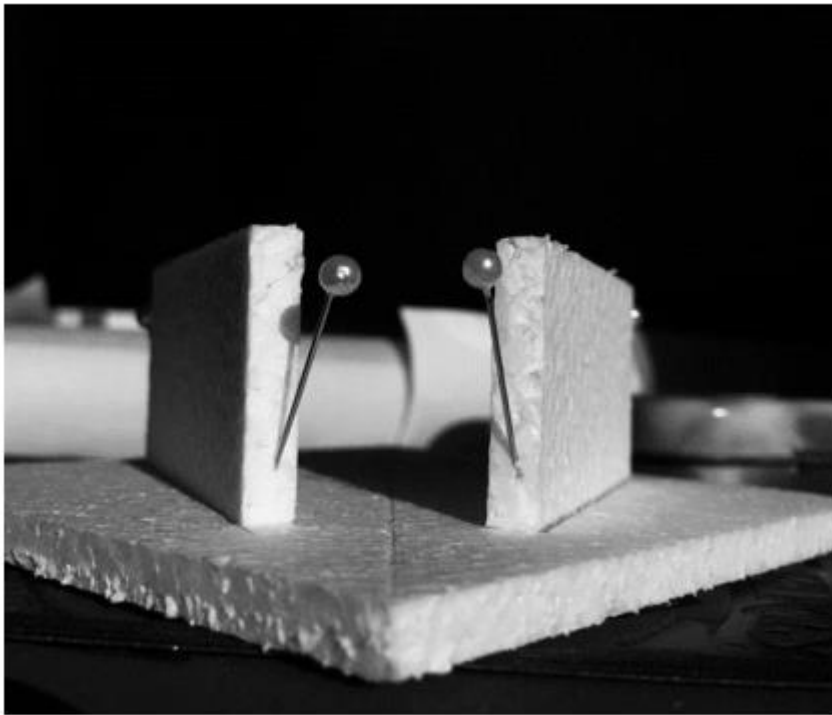

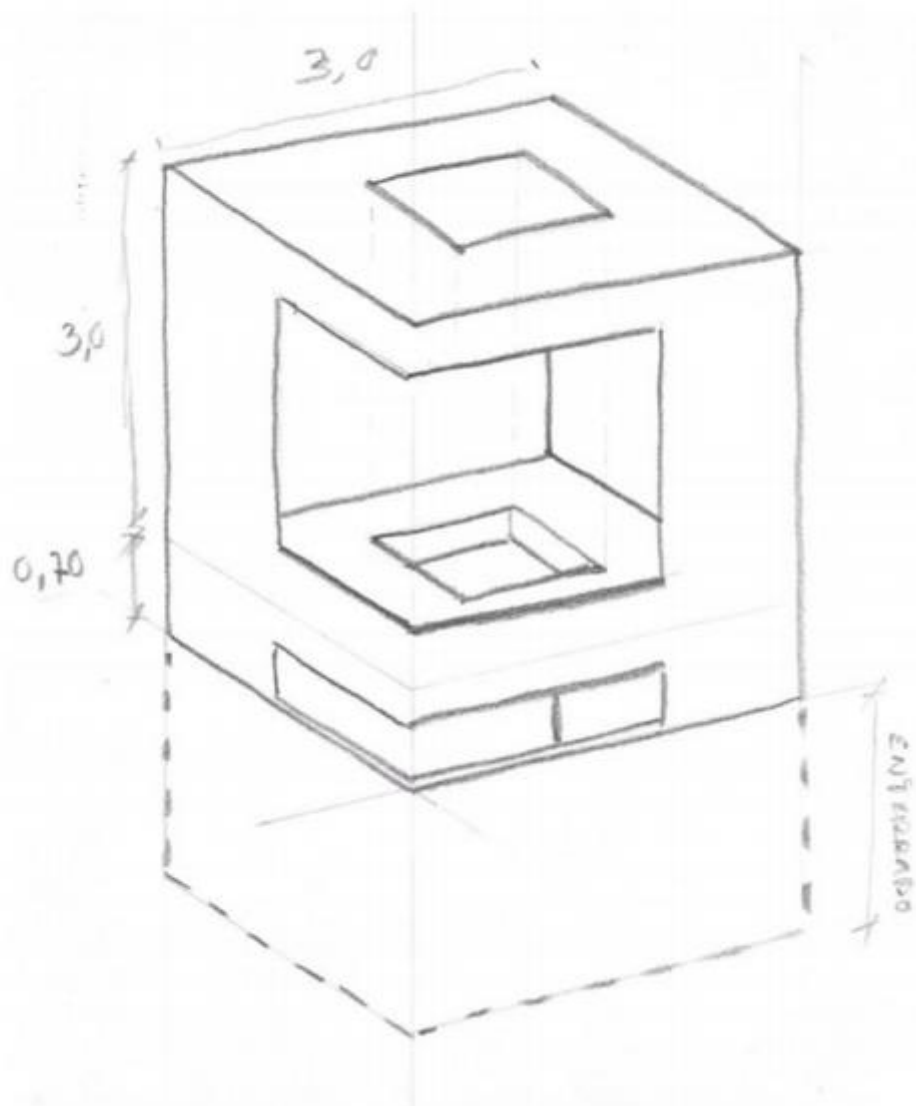

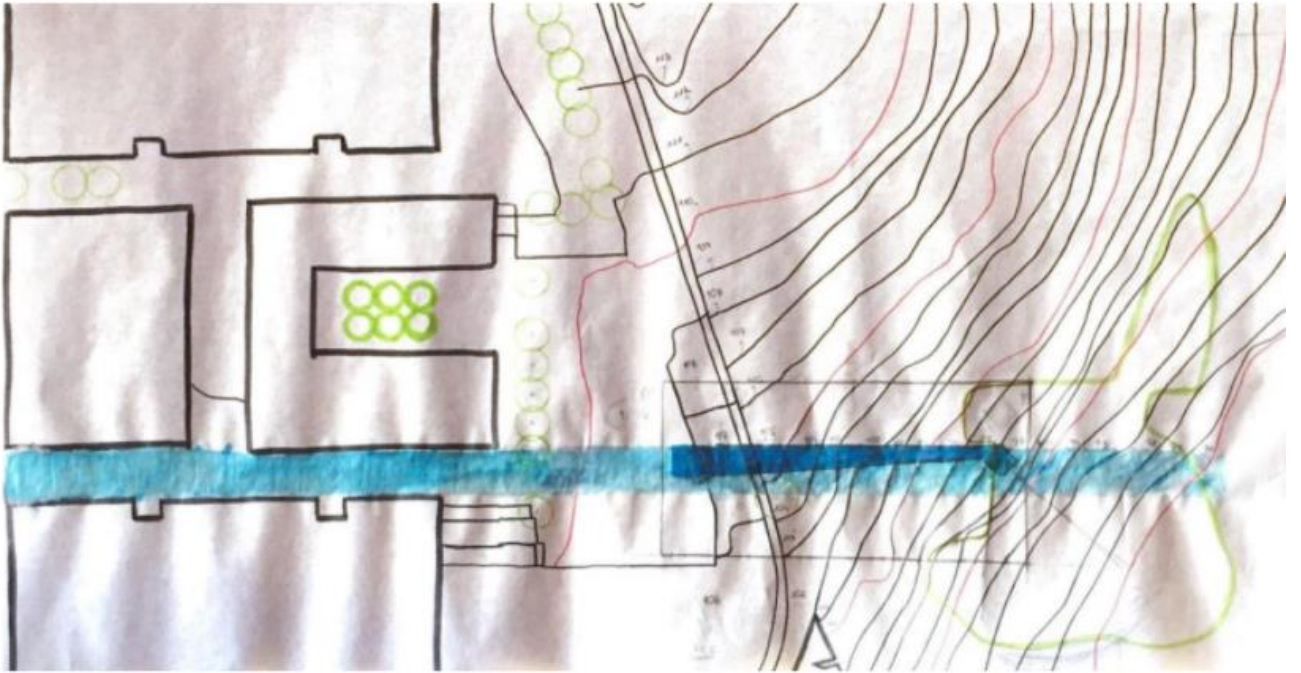

3.5. 1947

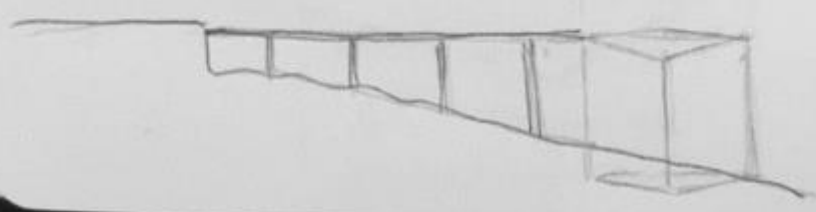
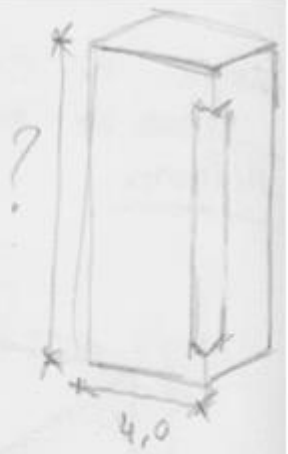
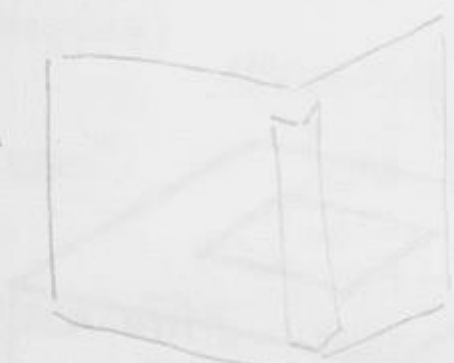



**Leituras comentadas**

### *Conversas com os estudantes das escolas de arquitetura, Le Corbusier, 1943*

Com este texto, entendo que como aluna de arquitetura, é necessário compreender os vários aspetos envolventes de quando se constrói um projeto.

Citando Le Corbusier *“A arquitetura é hoje uma atividade de se diz ser arte, palavra posta ali para servir de tapume às vaidades ou aos negócios. O ensino das escolas será capaz de alimentar, por si só, a dupla fonte da criação arquitetónica? Não creio. O coração parece ficar demasiado fora do circuito.”* – o meu entendimento desta frase é que hoje em dia, o valor espiritual de uma obra foi esquecido e que o título de arquiteto é meramente decorativo, apenas um título. Neste assunto eu concordo com Le Corbusier e sublinho a importância que os pormenores podem ter. Não apenas os pormenores finais e apenas decorativos, mas sim os pormenores estruturais de um projeto: a cor, a luz, as proporções do projeto, os materiais utilizados, o local de onde vai ser colocado, etc... todos estes aspetos são absolutamente cruciais porque são estes que o completam, que nos criam certos sentimentos, que podem criar memórias e que completam o projeto em si.



*The secret lives of buildings, Edward Hollis, 2009*

Quando um novo edifício é contruído dentro de uma cidade, esta construção criam um impacto temporário na vida das pessoas. Dependendo da visão do ser humano, este edifício pode ser bem visto ou mal, a visão é subjetiva.

Com este texto, Edward Hollis retrata lendas e histórias sobre diferentes tópicos como por exemplo a destruição do Pártenon. O Pártenon foi e continua a ser um símbolo da arquitetura e foi contruído como a idealização de uma sociedade perfeita. Descrita por Vitruvius mais tarde como um lugar confortável, equilibrado e forte, o Pártenon torna-se um marco no mundo da arte.

Mesmo que posteriormente tenha sido destruído ou se tenha vindo a autodestruir, o Pártenon, tal como os edifícios do quotidiano, serão todos lembrados eternamente como exemplos de arquitetura.

Arte e Técnica, Pierre Francastel, 1956

A arquitetura é uma arte que deriva da relação entre o homem e o espaço, quando houver necessidade de o espaço ser organizado de novo, a arquitetura desenvolve-se juntando a sociedade e o meio ambiente envolvente. Para que a arquitetura possa integrar as suas características através do campo da estética, deve seguir alguns caminhos visuais e alguns sensoriais para atrair as pessoas a este local. É neste contraste entre o cheio e o vazio que a arquitetura se desenvolve e na ideia estética que o Homem lhe coloca que atrai as outras pessoas a este projeto. Este método estético apura apenas o sentido da visão, mas os outros sentidos também têm que ser apurados: o olfato, o tato, a audição. São estes sentidos que dão sentido á Arquitetura.

### *A Construção do Sentido da Arquitetura, J.D. Gorjão Jorge, 2011*

O que eu apreendi com este texto é a capacidade que uma habitação tem em se conectar com o ambiente envolvente. O principal objetivo da arquitetura é encontrar um espaço que seja adequado. A sensação que nos é criada, quando entramos num hipermercado é diferente da sensação de quando entramos num espaço religioso ou um espaço que contenha uma certa mensagem subliminar por detrás. São estes sentimentos que nos guiam por entre os certos edifícios e que de certa forma nos controlam. Da mesma maneira que uma igreja nos dá este sentido de autorreflexão e de esperança, um hipermercado dá-nos a sensação de energia e uma certa responsabilidade. Estes momentos são muito distintos, mas ambos variam da mesma coisa: a arquitetura. É o espaço que nos envolve no momento que nos amplifica as sensações.

Em conclusão, é nestes pequenos e quase insignificantes momentos que se encontra verdadeira forma da arquitetura, nas sensações que nos criam, nas mensagens que nos transmitem e nas memórias que se constroem em torno da dela.